

TECHNICAL MANUAL
OPERATOR'S, UNIT AND
DIRECT SUPPORT MAINTENANCE MANUAL
(INCLUDING REPAIR PARTS AND SPECIAL TOOLS LIST)
FOR
BACHARACH COMBUSTIBLE GAS
ALARM SYSTEM

NSN 6665-00-410-4982

This technical manual is an authentication of the manufacturer's commercial literature and does not conform with the format and the content requirements normally associated with Army technical manuals. This technical manual does, however, contain all essential information required to operate and maintain the equipment.

Approved for public release; distribution is unlimited.

HEADQUARTERS, DEPARTMENT OF THE ARMY
28 SEPTEMBER 1990

This technical manual is an authentication of the manufacturer's commercial literature and does not conform with the format and the content requirements normally associated with Army technical manuals. This technical manual does, however, contain all essential information required to operate and maintain the equipment.

Approved for public release; distribution is unlimited.

SUPPLEMENTARY INTRODUCTORY MATERIAL

1-1. Maintenance Forms and Records.

Department of the Army forms and Procedures used for equipment maintenance will be those described by DA Pam 738-750, The Army Maintenance Management System.

1-2. Reporting Errors and Recommending Improvements.

You can help improve this manual. If you find any mistakes or if you know of a way to improve the procedures, please let us know. Mail your letters, DA Form 2028 (Recommended Changes to Publications and Blank Forms), or DA Form 2028-2 located in the back of this manual, directly to: Commander, U.S. Army Troop Support Command, ATTN: AMSTR-MCTS, 4300 Goodfellow Blvd., St. Louis, MO 63120-1798. A reply will be furnished to you.

1-3. Destruction of Army Material to Prevent Enemy Use.

Refer to TM 750-244-3 for instructions covering the destruction of Army Material to prevent enemy use.

1-4. Administrative Storage of Equipment.

a. Placement of equipment in administrative storage should be for short periods of time when a shortage of maintenance effort exists. Items should be in mission readiness within 24 hours or within the time factors as determined by the directing authority. During the storage period appropriate maintenance records will be kept.

b. Before placing equipment in administrative storage, current preventive maintenance checks and services should be completed. Shortcomings and deficiencies should be corrected, and all modification work orders (MWO's) should be applied.

c. Storage site selection. Inside storage is preferred for items selected for administrative storage. If inside storage is not available, trucks, vans, conex containers and other containers may be used.

BACHARACH

CD800/830/802/832
COMBUSTIBLE GAS
ALARM SYSTEMS

INSTRUCTION 23-9617
Revision 1 - October 1982

INSTRUCTION MANUAL

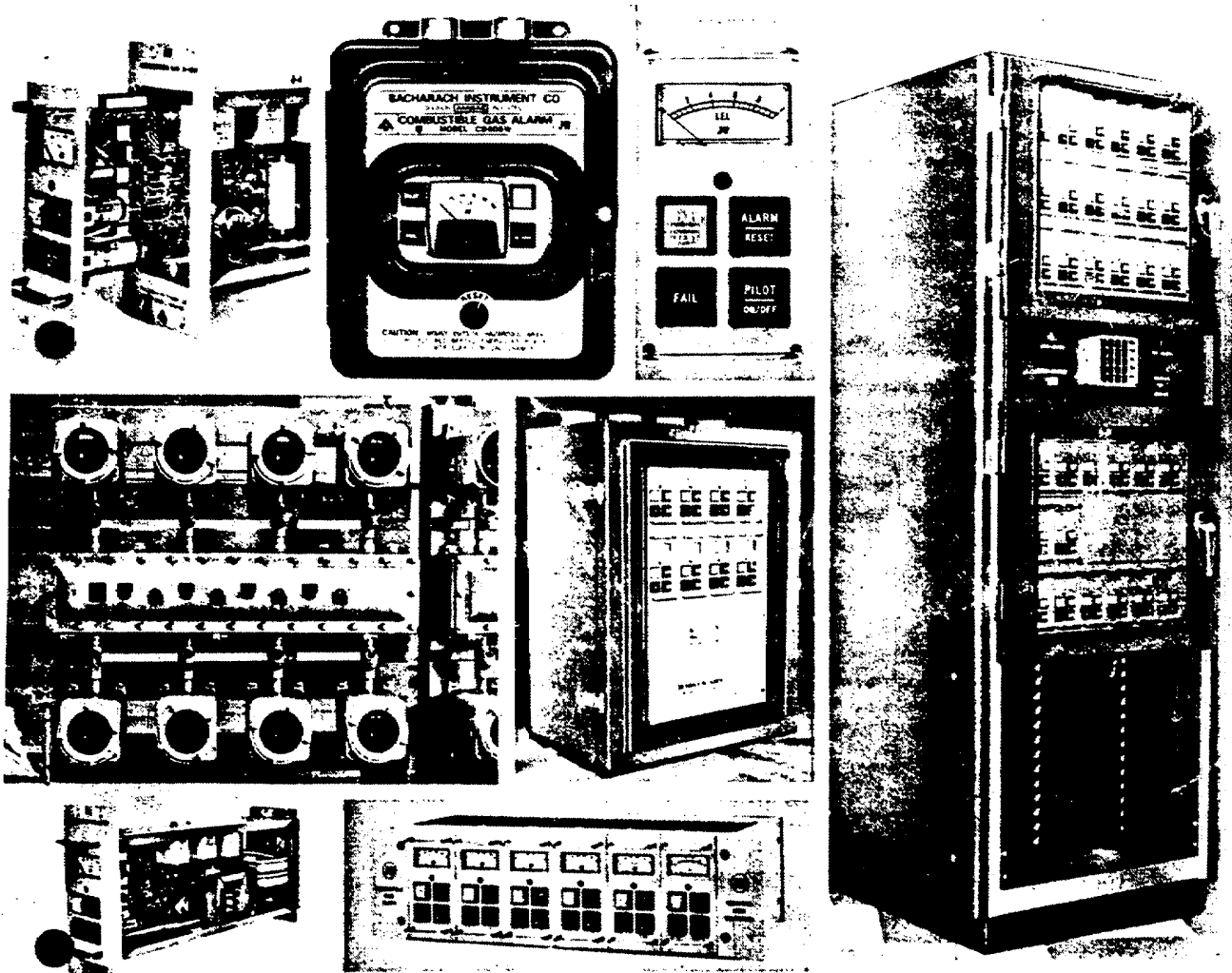

Bacharach, Inc.
625 Alpha drive, Pittsburgh, PA 15238 (412) 963-2000

Printed in U.S.A.

BACHARACH

ADDENDUM 1

INSTRUCTION 23-9617
CD800/830/802/832
COMBUSTIBLE GAS
ALARM SYSTEMS
Rev. 1 - October 1982

ERRATA:

Page 1-24 -- Part number 0051-7021 should be 0051-7065.

Page 1-25 -- Part number 0051-7021 should be 0051-7065.

Page 5-1 -- Part number 51-7012 should be 51-7046 and
Part number 51-7014 should be 51-7048.

Page 5-2 -- Part number 51-7041 should be 51-7063.

Page 5-3 -- Part number 51-7021 should be 51-7065.

Page 5-8 -- Part number 51-7041 should be 51-7063.

Page 5-9 -- Part number 51-7041 should be 51-7063.

DETECTOR WIRING - Throughout the manual reference is made to a three conductor cable (containing green, black, and white wires) for wiring the detectors to the system. The cable should be a **four** conductor cable containing red, black, white and green wires. The red wire is the active element A wire, the black wire is the reference element R wire and the white wire is the signal output C wire. The green wire is used to connect the detector head to chassis ground. A three conductor cable and a separate chassis ground wire is also acceptable. **The addition of the chassis ground wire is a requirement of several approval agencies.**

100% NITROGEN CALIBRATION CYLINEER 0023-4003 - Three times on page 3-2 and twice on page 3-7, 100% Nitrogen Calibration Cylinder 0023-4003 is mentioned to be used if combustible-gas-free air does not exit. This is in error, only Zero Gas/Dry Air Cylinder 0023-4004 should be used on catalytic sensors.

Addendum 1 to 23-9617
Rev. 0 - July 1987

Bacharach, Inc.
625 Alpha Drive, Pittsburgh, PA 15238 (412) 963-2000

WARRANTY

Bacharach, Inc., warrants to Buyer that at the time of delivery this Product will be free from defects in material and manufacture and will conform substantially to Bacharach Inc.'s applicable specifications. Bacharach's liability and Buyer's remedy under this warranty are limited to the repair or replacement, at Bacharach's option, of this Product or parts thereof returned to Seller at the factory of manufacture and shown to Bacharach Inc.'s reasonable satisfaction to have been defective; provided that written notice of the defect shall have been given by Buyer to Bacharach Inc. within one (1) year after the date of delivery of this Product by Bacharach, Inc.

Bacharach, Inc. warrants to Buyer that it will convey good title to this Product. Bacharach's liability and Buyer's remedy under this warranty of title are limited to the removal of any title defects or, at the election of Bacharach, to the replacement of this Product or parts thereof that are defective in title.

The warranty set forth in paragraph 1 does not apply to parts the Operating Instructions designate as having a limited shelf-life or as being expended in normal use.

THE FOREGOING WARRANTIES ARE EXCLUSIVE AND ARE GIVEN AND ACCEPTED IN LIEU OF (i) ANY AND ALL OTHER WARRANTIES, EXPRESS OR IMPLIED, INCLUDING WITHOUT LIMITATION THE IMPLIED WARRANTIES OF MERCHANTABILITY AND FITNESS FOR A PARTICULAR PURPOSE: AND (ii) ANY OBLIGATION, LIABILITY, RIGHT, CLAIM OR REMEDY IN CONTRACT OR TORT, WHETHER OR NOT ARISING FROM BACHARACH'S NEGLIGENCE, ACTUAL OR IMPLIED. The remedies of the Buyer shall be limited to those provided herein to the exclusion of any and all other remedies including, without limitation incidental or consequential damages. No agreement varying or extending the foregoing warranties, remedies or this limitation will be binding upon Bacharach, Inc. unless in writing, signed by a duly authorized officer of Bacharach.

TABLE OF CONTENTS

	<u>PAGE</u>
WARRANTY POLICY	i
<u>SECTION 1.</u> SYSTEMS DESCRIPTION	1-1
1-1 General Description	1-1
1-2 Gas Detector Units	1-1
1-2.1 Detector Sensing Device	1-2
1-2.2 Detector Electrical Circuitry	1-2
1-2.3 Detector Models	1-4
1-3 Control Modules	1-6
1-3.1 Control Module Circuitry	1-7
1-3.1.1 Power Supply	1-7
1-3.1.2 Signal Amplifier	1-7
1-3.1.3 Test Circuit	1-14
1-3.1.4 Warning Circuit	1-14
1-3.1.5 Alarm Circuit,	1-14
1-3.1.6 Delay Circuits	1-18
1-3.1.7 Fail Sensing and Relay Circuit.....	1-18
1-3.1.8 Alarm and Warning Reset Circuit	1-18
1-3.1.9 Display Meter	1-20
1-3.1.10 Relay External Circuits	1-20
1-3.2 Control Unit Models and Modular Configuration.....	1-23
1-3.2.1 Series 800 or 802 Single-Unit Configuration	1-23
1-3.2.2 Series 800 or 802 Multi-Module Configuration.	1-23
1-3.2.3 Series 830 and 832 Modular Multipoint Models.....	1-26
1-3.2.4 Special Configurations.....	1-26
1-3.3 Indicators, Controls, and Adjusters	1-26
1-3.3.1 Indicators	1-26
1-3.3.2 Controls.....	1-32
1-3.3.3 Adjusters	1-33
1-4 External Accessory Devices	1-35
<u>SECTION 2.</u> INSTALLATION.....	2-1
2-1 Location of Detectors.....	2-1
2-2 Location of Control Units	2-4

TABLE OF CONTENTS (continued)

		<u>PAGE</u>
2-3	Location of Warning Devices.....	2-4
2-4	Control Module Installation	2-4
2-4.1	CD800P	2-5
2-4.2	CD800W, CD802W	2-5
2-4.3	CD800X	2-5
2-4.4	CD830W4/W8, CD832W4/W8	2-5
2-4.5	CD830R6, CD832R6	2-5
2-4.6	CD830P6, CD832P6.....	2-5
2-4.7	CD830F, CD832F.....	2-5
2-5	Power Supply Connections.....	2-13
2-5.1	Power Connections.....	2-13
2-5.2	DC Secondary (Standby) Power Supply	2-13
2-5.3	Static Power Converter.....	2-13
2-5.4	12-Volt Lead-Acid Battery and Charger	2-21
2-6	Detector Installation.....	2-21
2-6.1	Installing Conduit	2-21
2-6.2	Installing Detector Wiring	2-22
2-6.2.1	Installing Single Detector on CD800/830 or CD802/832 Control Unit.....	2-23
2-6.2.2	Installing Second Detector on One Module, Models CD802/832.....	2-26
2-6.3	Installing Second Detector for CD800/830 Single-Channel Modules	2-26
2-6.4	Installing Wires for Alarm and Control Devices, All Models	2-27
2-6.5	Testing For Open Circuits, Short Circuits, and Leakage in Detector Wires	2-27
2-6.6	Connecting Conduit Wires to the Detector.....	2-27
2-6.7	Installing Detector on Conduit	2-27
2-6.8	Connecting Conduit Wires From the Detector to Control Module Assembly Terminals	2-27
2-6.9	Testing Operating Voltages and Compensating For Conduit Wire Voltage Drops.....	2-28
2-6.10	Detector Calibration	2-37
2-6.11	Installation of Plumbing For Sample Drawing Detector Assembly #0023-4017.....	2-37

TABLE OF CONTENTS (continued)

	<u>PAGE</u>
2-7	Warning and Alarm Circuit Modifications..... 2-37
2-7.1	Modification for Common Point Resetting 2-39
2-7.2	Modification for Automatic Warning and Alarm Reset..... 2-41
2-7.3	Modification for Automatic Warning with Manual Alarm Reset 2-41
2-8	Installation of External Accessory Devices 2-41
2-8.1	Installation of Recorder..... 2-42
2-8.2	Installation of Remote Reset Switch 2-42
2-8.3	Installation of Remote Alarm and Process Control Devices..... 2-42
2-8.4	"Horn Silence" or "Acknowledge" Option..... 2-42
<u>SECTION 3.</u>	<u>CALIBRATION AND ADJUSTMENTS</u> 3-1
3-1	General Objectives 3-1
3-2	Calibration..... 3-1
3-2.1	Calibrating a System with One Detector Per CD800/830 Control Unit..... 3-1
3-2.2	Calibrating a System with Two Detectors Per CD800/830 Control Unit..... 3-7
3-2.3	Calibrating A System For Volatile Hydrocarbons with Flash Points Below 70° F 3-9
3-3	Adjustments 3-11
3-3.1	Warning Circuit Adjustment..... 3-11
3-3.2	Alarm Circuit Adjustment..... 3-12
3-3.3	Test Adjustment 3-13
3-3.4	Recorder Output Adjustment 3-14
3-3.5	Checking Fail Circuits 3-14
<u>SECTION 4.</u>	<u>MAINTENANCE AND TROUBLESHOOTING</u> 4-1
4-1	Daily Inspection..... 4-1
4-2	Weekly Inspection 4-1
4-3	Monthly Maintenance 4-3

TABLE OF CONTENTS (continued)

		<u>PAGE</u>
4-3.1	Monthly Tests and Adjustments.....	4-3
4-3.2	Filter Screen Servicing.....	4-3
4-4	Special Maintenance Problems	4-4
4-4.1	Painting.....	4-4
4-4.2	Detector Immersion.....	4-4
4-5	Troubleshooting.....	4-4
4-5.1	General Preparation For Troubleshooting.....	4-4
4-5.2	Troubleshooting Charts	4-4
<u>SECTION 5.</u>	<u>PARTS LIST</u>	<u>5-1</u>

23-9617
7/1/76

ILLUSTRATIONS

FIGURE		PAGE
1-1	Detector Sensing Element	1-2
1-2	CD800/830 Detector Bridge Circuitry Schematic Diagram	1-3
1-3	CD800/830 and CD802/832 Combustible Gas Detector Models.	1-5
1-4	CD800/830 Printed Circuit Board Schematic Diagram	1-8
1-5	CD802/832 Printed Circuit Board Schematic Diagram	1-9
1-6	CD800/830 Series Control Module Block Diagram	1-10
1-7	CD802/832 Dual-Channel System Simplified Block Diagram	1-11
1-8	Schematic Diagram of Power Supply	1-12
1-9	CD800/830 Signal Amplifier and Test Circuits (typical for CD802/832 circuitry also)	1-13
1-10	CD800/830 Warning Circuitry Schematic Diagram (typical for Alarm Circuitry)	1-15
1-11	Time Delay Circuit CD802/832 Schematic Diagram	1-17
1-12	Fail Circuit Schematic Diagram	1-19
1-13	CD800/830 Relay External Circuits and Typical External Connections	1-21
1-14	CD802/832 Relay External Circuits and Typical External Connections	1-22

ILLUSTRATIONS (continued)

FIGURE		PAGE
1-15	Series 800 and 802 Single-Module Models	1-24
1-16	Multipoint Systems Configuration	1-25
1-17	CD830W, CD832W Wall Mounting Cabinet and CD830, CD832F Floor Standing Cabinet Multi- point Control Module Configuration	1-27
1-18	Forced Cooling Unit Assembly (115V) for Floor- standing Cabinet	1-28
1-19	CD800P and CD800PF Mounting Enclosures with CD830 plug-in Control Modules, Showing Indicators, Controls, and Adjusters	1-29
1-20	Front Panel Configurations, CD800W, CD802W Systems	1-30
1-21	CD832 Controls and Indicators for Dual-Channel Systems	1-31
1-22	CD802/832 Circuit Board Relays and Adjuster for Dual-Channel Systems.....	1-34
2-1	Typical Location Points for Detectors	2-2
2-2	Typical Through-Bulkhead Installation	2-3
2-3	CD800P Control Unit Installation Data.....	2-6
2-4	CD800W and 802W Wall-mounting Cabinet Installation.....	2-7
2-5	Installation of Circuit Board Standoffs for CDSOOW and CD802W Cabinets Without Factory-Installed Conduit Hubs.....	2-8
2-6	CD800X and CD802X Control Unit	2-9

ILLUSTRATIONS (continued)

FIGURE		PAGE
2-7	CD830W8 Wall-Mounting Cabinet for up to Eight Control Modules (23-7176), or CD830W4 (23-7175) for up to Four Control Modules (with top rack covered)	2-10
2-8	CD830 and CD832 Standard Instrument Rack Adapter for Up to Six Control Modules.....	2-11
2-9	CD830 Floor-standing Instrument Cabinet	2-12
2-10	Transformer Wiring for 115 VAC and 230 VAC External Power.....	2-13
2-11	CD800W and 0CD802W External Wiring Connections Diagram	2-15
2-12	CD800X and CD802X External Wiring Connections Diagram	2-16
2-13	CD800P and CD802P External Wiring Connections Diagram (CD800P or PF Enclosure).....	2-17
2-14	CD830W4/CD830W8 and CD832W4/CD832W8 External Wiring Connection Diagram.....	2-18
2-15	CD830R6 and CD832R6 External Wiring Connections Diagram	2-19
2-16	CD Converter Terminal Connection Diagram CD830R6	2-20
2-17	Wire Size/Length/Resistance Graph.....	2-24
2-18	Alternate Four and Six Leadwire Connections Between Control Module and Detectors of Paired Detector System.....	2-25
2-19	Detector Model 800-086 Exploded View	2-29

ILLUSTRATIONS (continued)

FIGURE		PAGE
2-20	Detector Model 0023-4012 Exploded View	2-30
2-21	Detector Model 0023-4014 Exploded View	2-31
2-22	Detector Model 0023-4017 Exploded View	2-32
2-23	Detector Model 0023-7317 Exploded View	2-34
2-24	Use of Test Socket Adapter 0023-4027 to Determine Detector Operating Voltage	2-35
2-25	Recommended Sample Flow Connections	2-38
2-26	Lamp/Lens Replacement	2-40
2-27	Modification Point for Warn and Alarm Automatic Reset	2-40
2-28	#0023-4080 Reset Switch with Mounting Hardware and Wiring	2-40
2-29	Typical Recurrent Alarm Circuitry (Optional).....	2-44
3-1	Use of Test Kit Dispensing Valve and Regulator Assembly, Gas Cylinder, and Sample Cup(s) at Diffusion Detectors for System Calibration Tests.	3-3
3-2	Calibration Percent L. E. L. Equivalents for Gases Other Than Propane, with Propane Used as Calibrating Gas	3-5
4-1A	Troubleshooting Chart 1: Zeroing Meter Pointer	4-6
4-1B	Troubleshooting Chart 2: Adjusting Warn and Alarm Levels	4-7
4-1C	Troubleshooting Chart 3: Adjusting for Full- scale Deflection of Meter Pointer.....	4-8
4-1D	Troubleshooting Chart 4: Fail Circuit Testing and Repairs.....	4-9
4-1E	Troubleshooting Chart 5: Calibrating Meter Response to Gas Concentration Levels.	4-10

TABLES

		PAGE
2-1	AC Power Terminal Connections CD800/830 Series Models	2-14
2-2	Resistance of Standard Annealed Copper Wire (Values are approximately, and will depending upon resistivity of specific conductor used.)	2-23
2-3, 2-4	Relay Switching Terminals For External Device	2-43
3-1	Multiplying (K) Factors for Conversion of Propane Gas % L. E. L. to % L. E. L. Readings for Other Gases.....	3-6
3-2	Percent L. E. L. Reading with 0.2 cc Vaporized Volatile Liquid in One Gallon of Air	3-10

23-9617
9/19/77

SECTION 1

SYSTEMS DESCRIPTION

1-1 GENERAL DESCRIPTION

The CD800/830 and CD802/832 Series Combustible Gas Alarm Systems comprise several configurations of gas detectors and control units designed to measure concentrations of combustible gases wherever they occur. When properly installed, the systems continuously monitor atmospheres and give early warnings of combustible gas leaks, flammable liquid spills, and other dangerous combustible gas or vapor conditions. Typical standard features include state-of-the-art design with all solid-state electronics for maximum reliability, meter display for instantaneous readout of percent Lower Explosive Limit (L.E.L.), recorder outputs, and a dual alarm level capability. Built-in relays are provided that may be used to actuate various plant protection devices such as ventilation fans and blowers, sprinklers, shut-down controls, or process control switches.

The CD800/830 and CD802/832 systems are similar except that the CD802/832 control units have two discrete signal channels to monitor two points individually, whereas CD800/830 individual control units have only one signal channel to monitor a single point. (If a CD800/ 830 control unit is used to monitor two points, incoming signals are summed in the single channel as if from a single point.)

1-2 GAS DETECTOR UNITS

To detect combustible gas in air, the existing air-gas mixture surrounding a detector is subjected to flameless catalytic burning on the surface of a catalyst-coated sensing element. The resulting heat raises the temperature, and thus the electrical resistance, of the active sensing element. A Wheatstone Bridge circuit is used to compare the electrical resistance of the active sensing element with that of a companion reference element (noncatalytic and therefore inactive) at the same ambient temperature. The difference in electrical resistance between the active and reference elements produces a signal current in the detector bridge circuit which is fed to the remotely located control unit, where it is in turn electrically processed to drive an indicating meter and associated alarm circuitry.

23-9617
7/1/76

1-2 GAS DETECTOR UNITS (continued)

With the sensing element surrounded by a double flame arrestor, the detector is suitable for location in Class I, Divisions 1 and 2, Groups A, B, C, and D hazardous locations as defined by National Electrical Codes.

NOTE: Standard detectors should not be used in oxygen-enriched atmospheres. Special detectors should be chosen for such atmospheres in consultation with the factory. Oxygen-deficient and inert atmospheres may be monitored by standard detectors if sampled gases are diluted by air to support an oxidation reaction on the catalytic surface of the sensing element.

1-2.1 DETECTOR SENSING DEVICE. (Figure 1-1) The sensing element of the combustible gas detector is a platinum-covered bead protected by a porous metal, cylindrical cap that freely passes gas and air while excluding airborne, nongaseous materials from the area surrounding the element. Individual elements for use in CD800/830 Series detectors normally sense the presence of combustible gases of any kind. Elements are also available with special sensitivities to particular gases such as methane, hydrogen, or ethylene oxide.

The sensitivity of all catalytic materials may be inhibited by certain compounds, usually called "poisons." Tetraethyl lead and silicone compounds are the most critical. J-W sensing elements utilize a unique design and are resistant to catalytic poisoning. But aerosol sprays, polishes, waxes, and lubricants containing silicones should not be used in the vicinity of sensing elements. Where poisons cannot be eliminated, frequent gas testing is essential to ensure safe and accurate operation of the gas detection system.



Figure 1-1. Detector Sensing Element

1-2.2 DETECTOR ELECTRICAL CIRCUITRY. (Figure 1-2) Regulated 6-volt (nominal) DC power from the control module is applied to balanced pairs of resistances in the detector. In normal atmospheres free of combustible gases, the paired resistances are in electrical balance, so that no signal current is sensed by the measuring circuit of the control unit. Oxidation of combustible gas on the catalytic element acts to increase its resistance,

23-9617
7/1/76

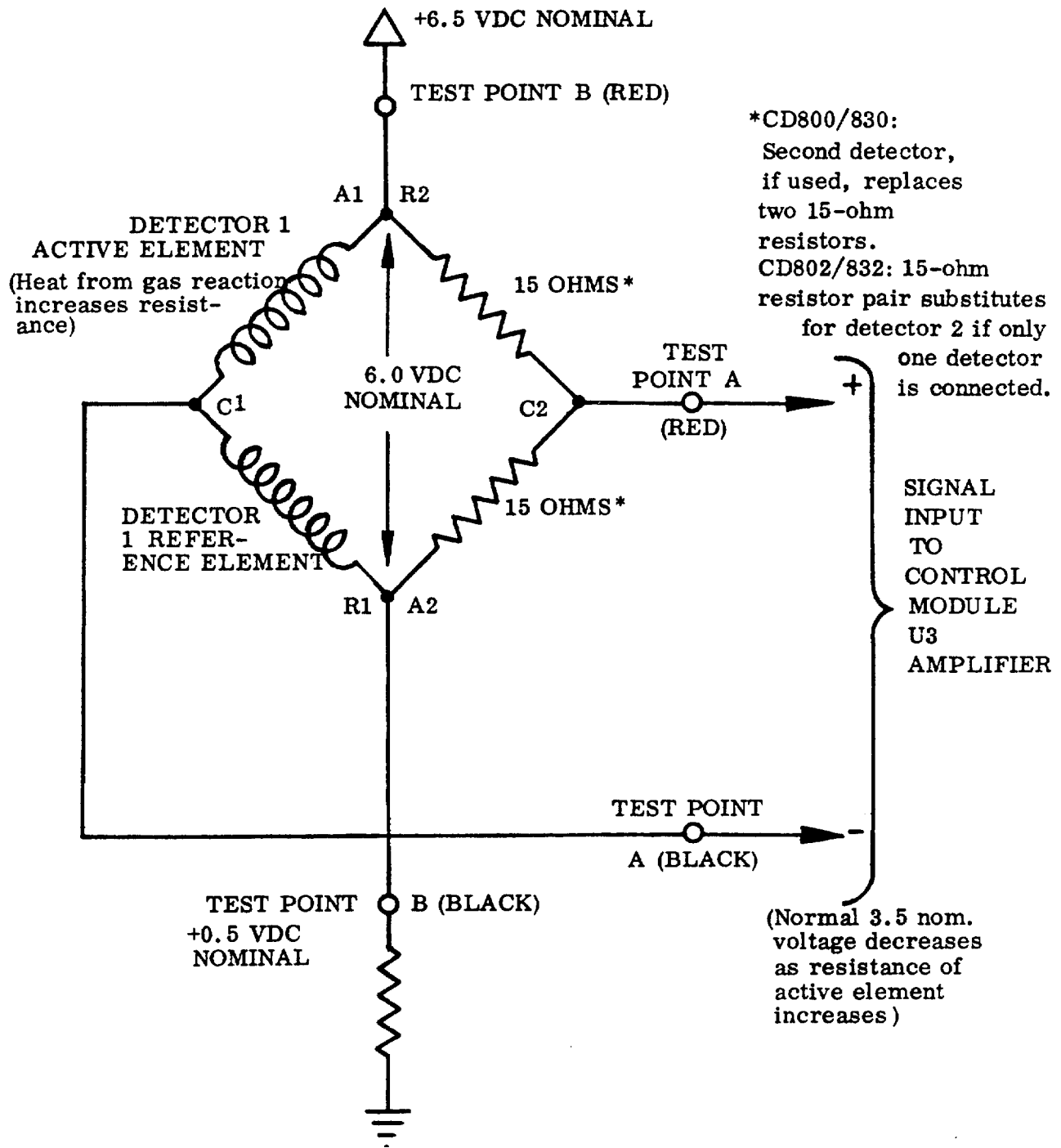

Figure 1-2. CD800/830 Detector Bridge Circuitry Schematic Diagram

23-9617
7/1/76

1-2 GAS DETECTOR UNITS (continued)

1-2.2 Detector Electrical Circuitry (continued)

thus disturbing the electrical balance of the paired resistances. The resulting voltage changes are in proportion to the concentration of gas in the atmosphere surrounding the detector.

Automatic compensation for changes in ambient temperature, humidity, and pressure is provided by the reference element in the opposite half of the resistance bridge. As the opposing companion element changes resistance with changes in ambient air conditions--exactly as does the sensing element-- the bridge remains in balance. Therefore only the combustible gas-to-air proportional mix, independent of other atmospheric conditions, will produce an output signal from the detector.

For CD800/830 (single-channel) models, a matched pair of 15-ohm resistors installed on the control module terminal strip, Figure 1-2, can be removed and replaced by leadwires to a second detector to provide more intensive monitoring of a critical area. Readings then sum gas conditions at both detectors so that, for example, a 20-percent L. E. L. reading may equal 10 percent plus 10 percent or 14 percent plus 6 percent, etc. Such installations do not indicate at which of the two detectors the more dangerous atmospheric condition prevails, therefore the installation of single-channel systems with two detectors should be limited to areas where corrective or protective measures can be applied in the vicinity of both detectors at once.

Conversely, CD802/832 (dual-channel) models designed to monitor two detectors independently may be used to monitor only a single detector. If so, a matched pair of 15-ohm resistors must be installed on the control module terminal strip in place of the leadwires from a second detector.

1-2.3 DETECTOR MODELS. (Figure 1-3) Different environments frequently require different detector housings and air sampling techniques. Five detector models (for which up-to-date Factory Mutual and Canadian Standards Association listing are available from the manufacturer) are available to meet these varying needs:

- (1) Models 23-4012: remote mounting, explosion-proof, weatherproof detector housing; diffusion sampling (Figure 1-3). Approved for use in hazardous areas as defined by the National Electrical Code (N. E. C.), Class I, Division 1, Groups A, B, C, and D.
- (2) Model 23-4014: duct-mounting, explosion-proof detector housing; diffusion sampling (Figure 1-3). Approved for use in N. E. C. Class I, Division 1, Groups A, B, C, D hazardous areas. Because the mounting plate may not be a suitable interface between Division 1 and less hazardous areas, this 23-4014 detector is approved for use entirely within a Class I, Division 1 area, or for insertion into a Class I, Division 2 area.

23-9617
7/1/76

Model 23-4012:

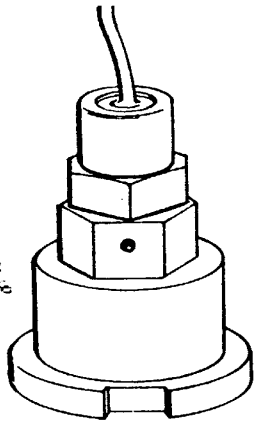

Remote mounting, weatherproof, explosion-proof, diffusion sampling



Model 23-4017: Remote mounting, weatherproof, explosion-proof, sample drawing

Model 23-4014:

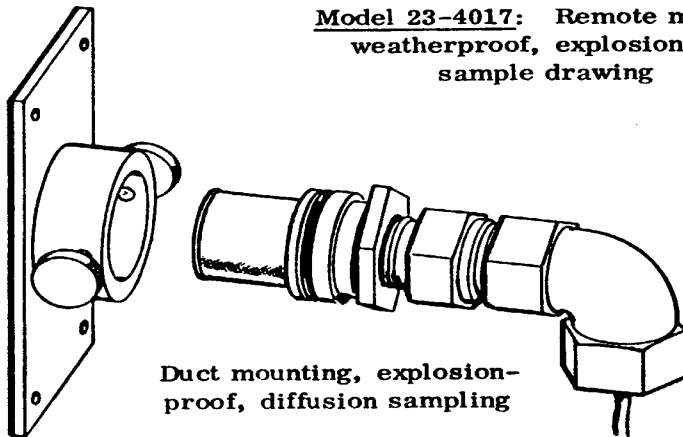

Duct mounting, explosion-proof, diffusion sampling

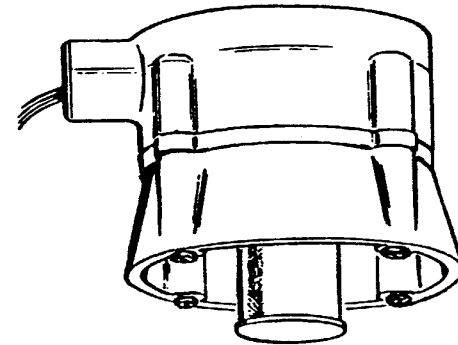

Model 800-086:

Remote mounting, weatherproof, explosion-proof, diffusion sampling

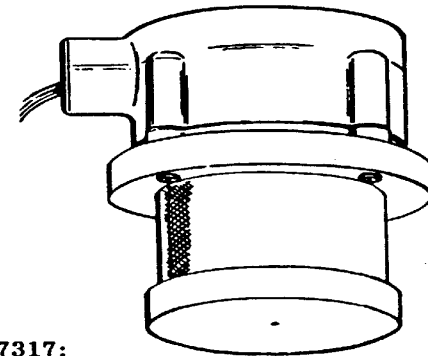

Model 23-7317:

Remote mounting, weatherproof, explosion-proof, diffusion sampling, high-humidity shield, corrosion-proof

Figure 1-3. CD800/830 and CD802/832 Combustible Gas Detector Models.

1-2 GAS DETECTOR UNITS (continued)1-2.3 Detector Models (continued)

- (3) Model 23-4017: remote mounting detector housing with integral air aspirator for continuous sample drawing. Sample gas is transported to the sensor through a length of tubing from enclosed areas, tanks, and vessels not otherwise readily accessible; from high-velocity gas streams; from areas containing more dirt or moisture than desirable for diffusion sampling; from nitrogen-inerted atmospheres where air blending is required; from elevated-temperature areas (200° F or higher); or any situation where sample conditioning is required. (For example: If flash point of combustible material is greater than 70° F, sample line and detector must be heated to above flash point.) Approved for use in N.E.C. Class I, Division 1, Groups A, B, C, and D hazardous areas.
- (4) Model 800-086: explosion-proof, weatherproof detector housing; diffusion sampling (Figure 1-3). Approved for use in N.E.C. Class I, Division 1, Groups B, C, and D hazardous areas.
- (5) Model 23-7317: explosion-proof, weatherproof housing; diffusion sampling; high-humidity shield to protect sensor element from heavy moisture content in the air (Figure 1-3). Approved for use in N.E.C. Class I, Division 1, Groups B, C, and D hazardous areas.

Catalytic sensor elements in all models have flame arrestors caps to prevent ignition of combustible gases in the air. Each detector assembly has a 5-layer mesh monel screen enclosing the plug-in sensing element, providing redundant flame-arresting protection.

1-3 CONTROL MODULES

All CD800/830 and 802/832 control modules contain power regulating and signal processing circuitry, percent L. E.L. indicating meter, indicator lights to signal gas conditions and system operating modes, circuit adjusters, and relays in small, compact units.

CD800/830 series and CD802/832 series control modules differ in that each CD800/830 control module ordinarily monitors a single detector (or if two, the signals from both are summed as if for one), whereas each CD802/832 control module incorporates two discrete channels for the independent monitoring of signals from two detectors. The CD802/832 control module features a channel selector control that can be set either to AUTO (automatic mode), in which meter and signal lights respond to the channel receiving the strongest signals from the detectors, or to either of two channel positions, in which meter and signal lights respond to the channel selected. Alarm, warning, and failure circuitry and indicators remain active for both channels, regardless of the channel-selector control position.

23-9617
7-1-76

1-3 CONTROL MODULE (continued)1-3.1 CONTROL MODULE CIRCUITRY. All models have circuitry to perform the following functions:

- (1) Supply regulated power to detector(s)
- (2) Signal detector power circuit failures
- (3) Receive detector electrical (gas analog) signal inputs
- (4) Compare signals with internal reference voltages to trigger warning and alarm signals in response to excessive gas concentrations at the detector(s)
- (5) Simulate gas signals for control module circuitry self-test in response to operation of the TEST pushbutton
- (6) Reset "latched" warning and alarm internal relays by operation of the RESET pushbutton

The function and operation of the various internal circuits incorporated for these purposes may be described as follows (See Figures 1-4 through 1-7.):

1-3.1.1 Power Supply. (Figure 1-8) Line voltage at 115 or 230 volts, 50/60 Hz, at 0.1 amp is transformed to a nominal 12 VAC input to the power supply, where it is rectified in a diode bridge rectifier component (U1 for CD800/830; U6 for CD802/832) within 1 percent in a miniature voltage regulator (U2 for CD800/830; U5 for CD802/832) when the power to the module is on (glowing green pilot light on panel). DC input terminals are provided for connecting directly to a 12-volt battery where desired. Both line and battery power may be connected simultaneously, with the battery on standby duty in the event of line power failure. The control electronics consumes approximately 15 watts of power. Two outputs, at nominal 13-volt and 6-volt levels, are provided from the power supply. A 100-ohm potentiometer (R2) in the 6- volt supply permits output voltage level adjustments to compensate for line voltage losses in conductors to and from remote detectors.

1-3.1.2 Signal Amplifier. (Figure 1-9) The signal amplifier circuit consists of a differential amplifier (U3 for CD800/830; U1 for CD802/832) and associated components, connected to signal and reference voltages. With fresh air at the detector, both amplifier inputs remain at a nominal 3.5-volt operating level. Therefore no voltage difference appears and no amplification occurs. Catalytic oxidation of a combustible gas on the detector sensor element, however, increases the temperature and thus the resistance of the sensor element, resulting in a voltage imbalance in the bridge circuit of which the

23-9617
7/1/76

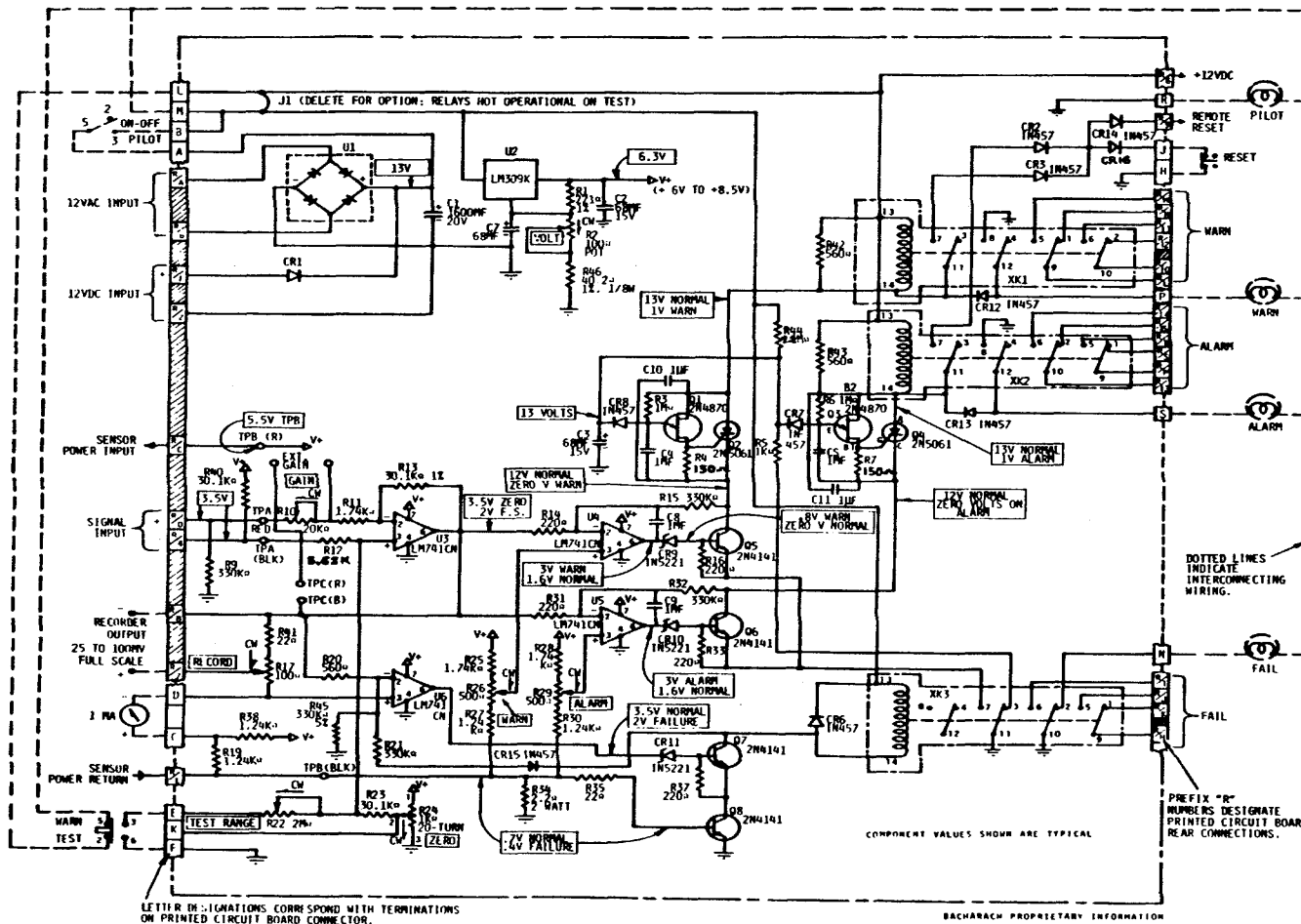

Figure 1-4. CD800/830 Printed Circuit Board Schematic Diagram

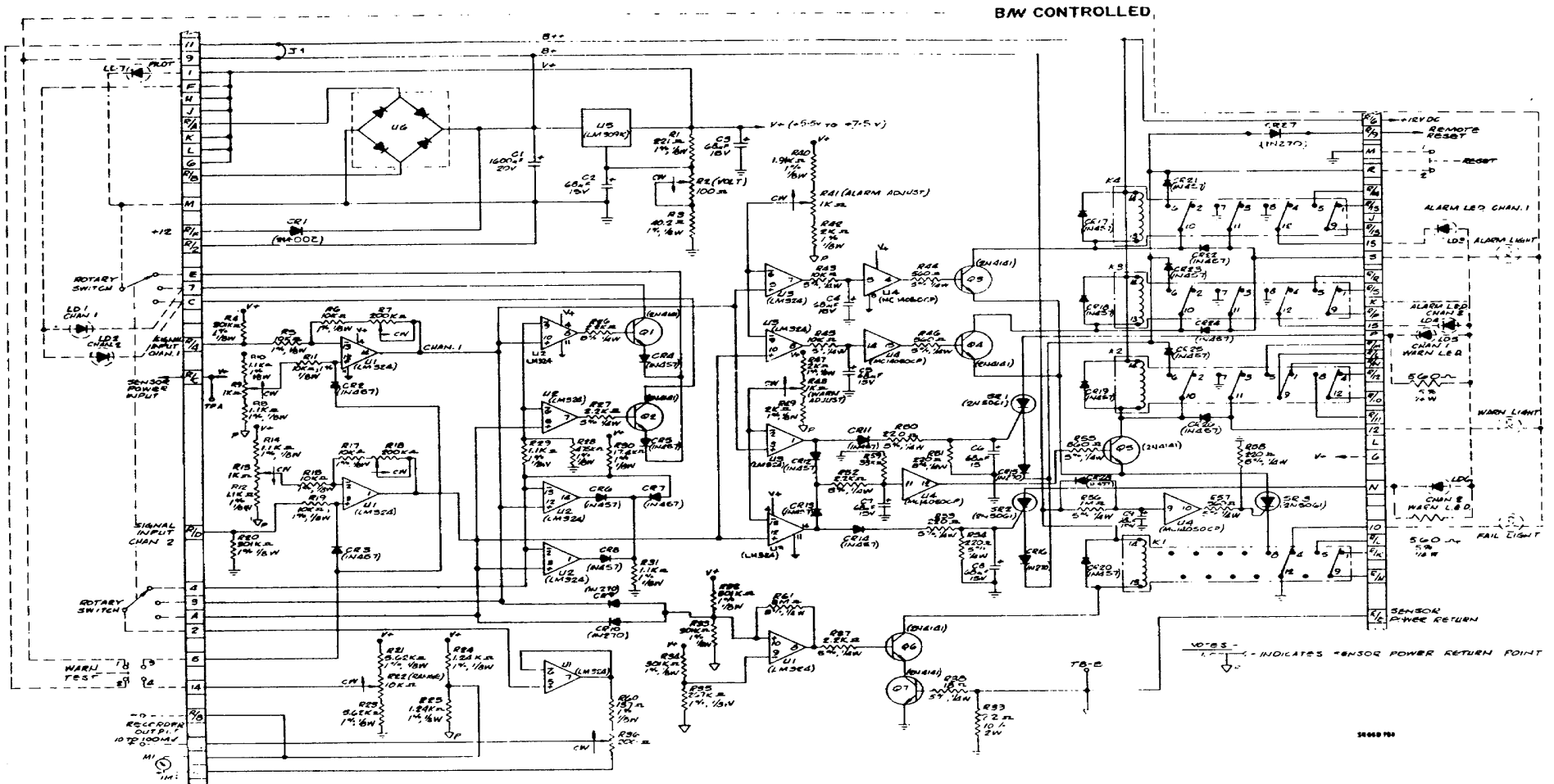

Figure 1-5. CD802/832 Printed Circuit Board Schematic Diagram

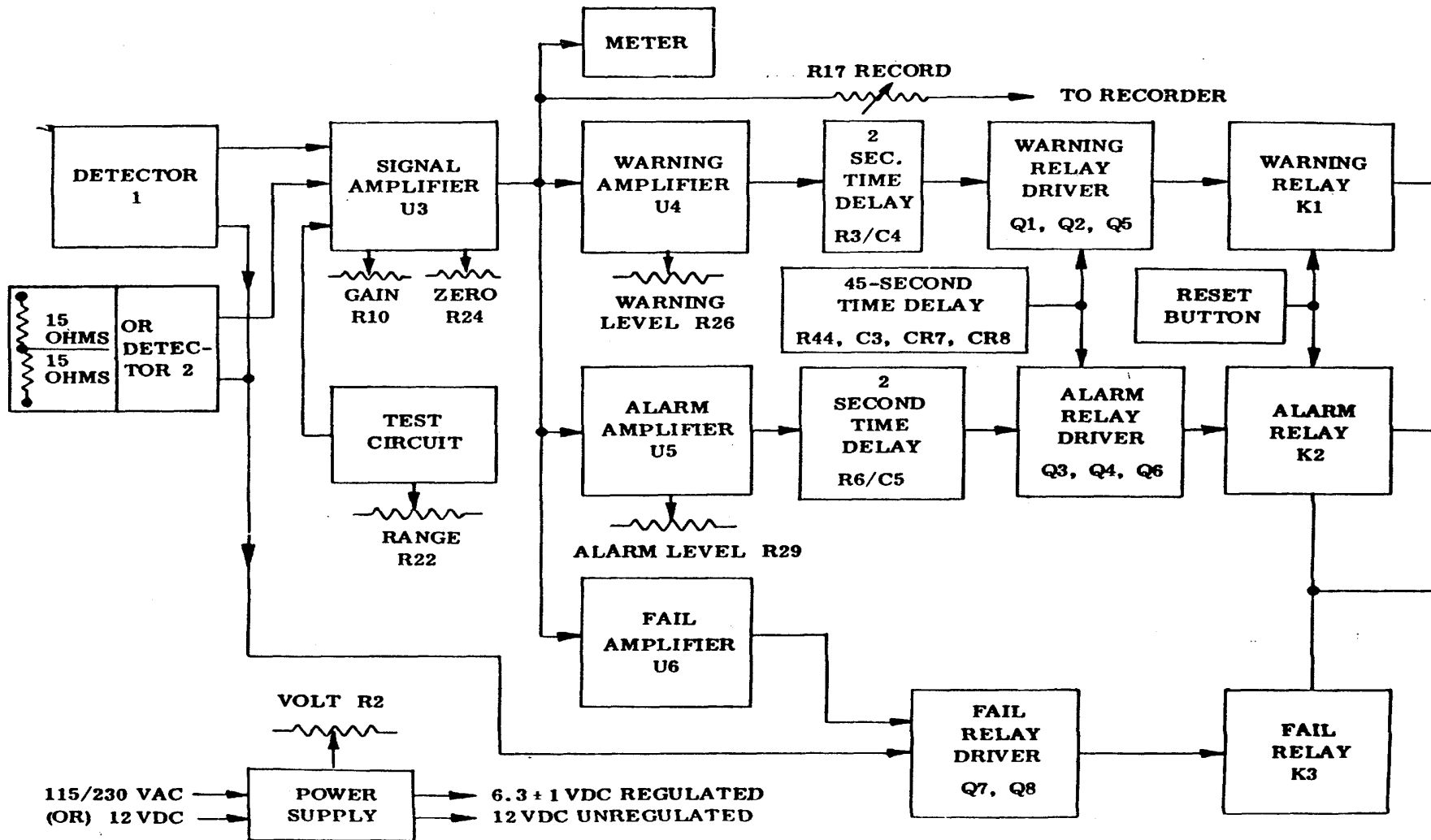

Figure 1-6. CD800/830 Series Control Module Block Diagram

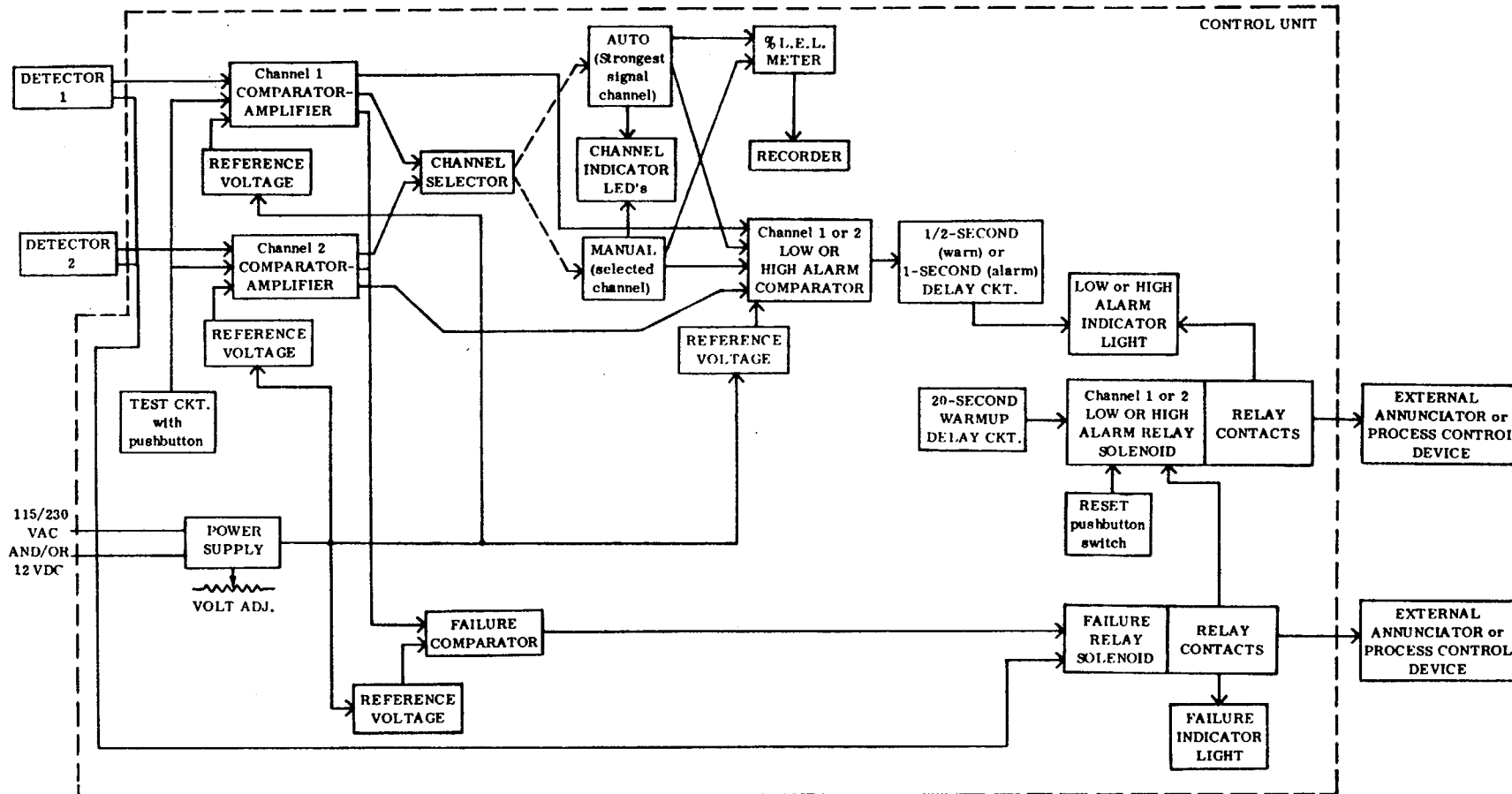

Figure 1-7. CD802/832 Dual-channel System Simplified Block Diagram

23-9617
7/1/76

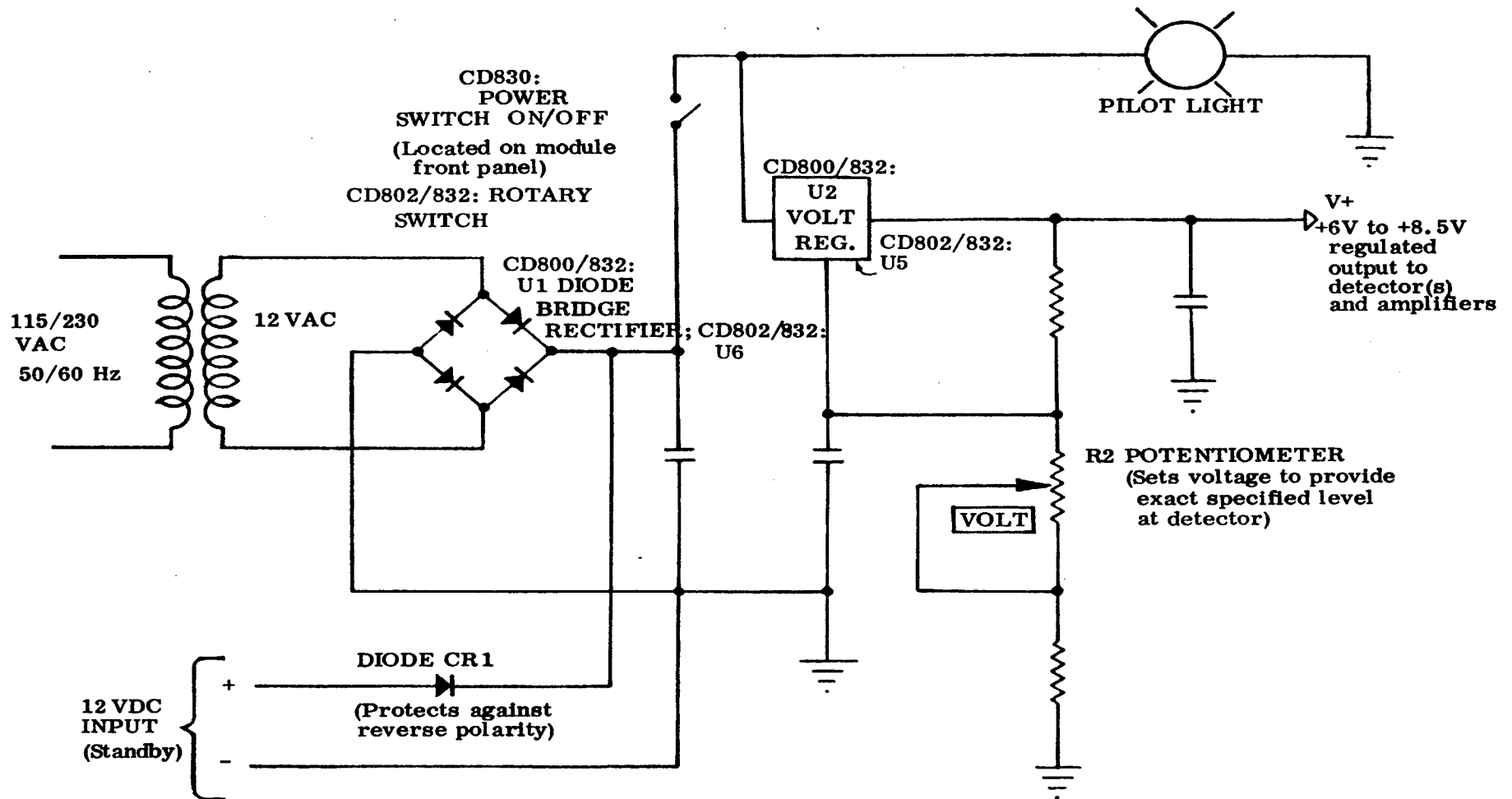

Figure 1-8. Schematic Diagram of Power Supply

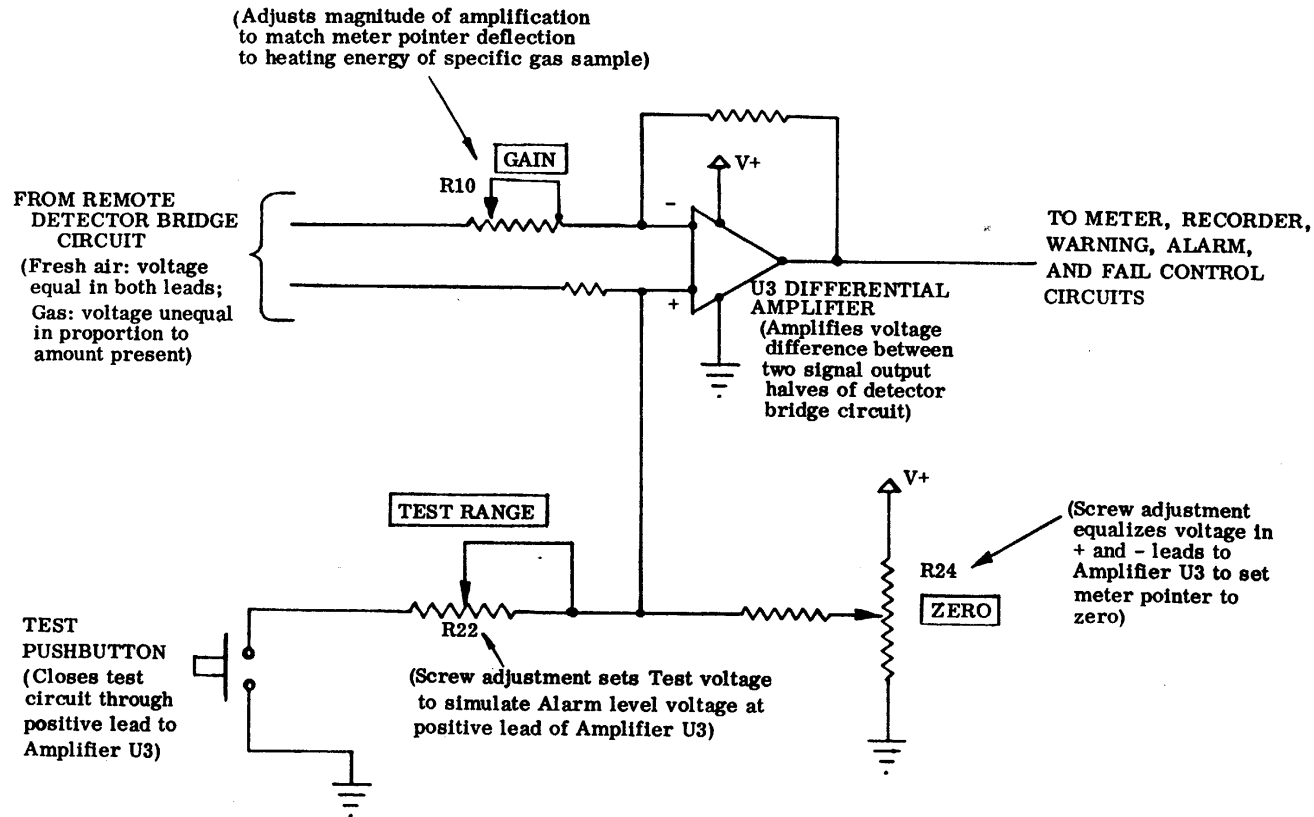

Figure 1-9. CD800/830 Signal Amplifier and Test Circuits (typical for CD802/832 circuitry also)

1-3 **CONTROL MODULE (continued)**

1-3.1.2 **Signal Amplifier (continued)**

sensor is a part. A differential voltage then appears between the two amplifier inputs and amplification occurs. The resulting amplifier output is applied to the percent L. E. L. meter and to the warning, alarm, recorder, and failure detection circuits that follow.

1-3.1.3 **Test Circuit.** (Figure 1-9) The test circuit is provided to simulate gas alarm conditions by pushbutton action. When the TEST pushbutton on the control module front panel is depressed, a circuit is closed from ground through potentiometer R22 to the + input of differential amplifier U3 of CD800/830 or U1 of CD802/832. The result is an imbalance between the two inputs to U3 or U1 such as would be caused by the detection of a 100- percent L. E. L. gas-air mixture at the detector. A screw-adjustment setting of the RANGE potentiometer R22 controls the signal level to the amplifier to drive the indicating meter to full scale with the TEST push- button depressed. Since the signal displayed on the meter is also a function of signal amplifier gain, as established by the GAIN adjustment potentiometer (R10 for CD800/830; R9 and R13 for CD802/832), RANGE control R22 may require slight readjustment if the gain setting (U3 for CD800/830; U1 for CD802/832) is altered during a calibration check. When the proper setting of R22 has been made, the ALARM and WARN lamps and relays respond to operation of the TEST pushbutton as if in an actual alarm condition, so that the operation of the control module circuitry and external warning devices may be evaluated for purposes of maintenance.

1-3.1.4 **Warning Circuit.** (Figure 1-10) The control module warning circuitry operates from the amplified detector output and an adjustable reference voltage. The reference voltage is usually set at a level equivalent to an amplified detector signal representing a gas-air mixture of 20 percent of the Lower Explosive Limit (20% L. E.L.). Both the amplified detector output and the reference voltage are applied to a voltage comparator (U4 for CD800/830; U3 for CD802/832). If the signal level is below the reference voltage, the base of transistor Q5 is negative, and Q5 is in the "off" state. When the amplified signal exceeds the reference voltage level, a positive voltage of sufficient magnitude to "turn on" transistor Q5 causes current to flow through the transistor to energize the warning light and relay. Any audio or visual warning devices connected to the relay output terminals may be controlled in this manner. The warning reference voltage level is set by means of a screw adjustment on WARN potentiometer R26 for CD800/830 or R48 for CD802/832. Transient pulses are prevented from energizing the warning circuit by means of a time delay circuit described below.

23-9617
7/1/76

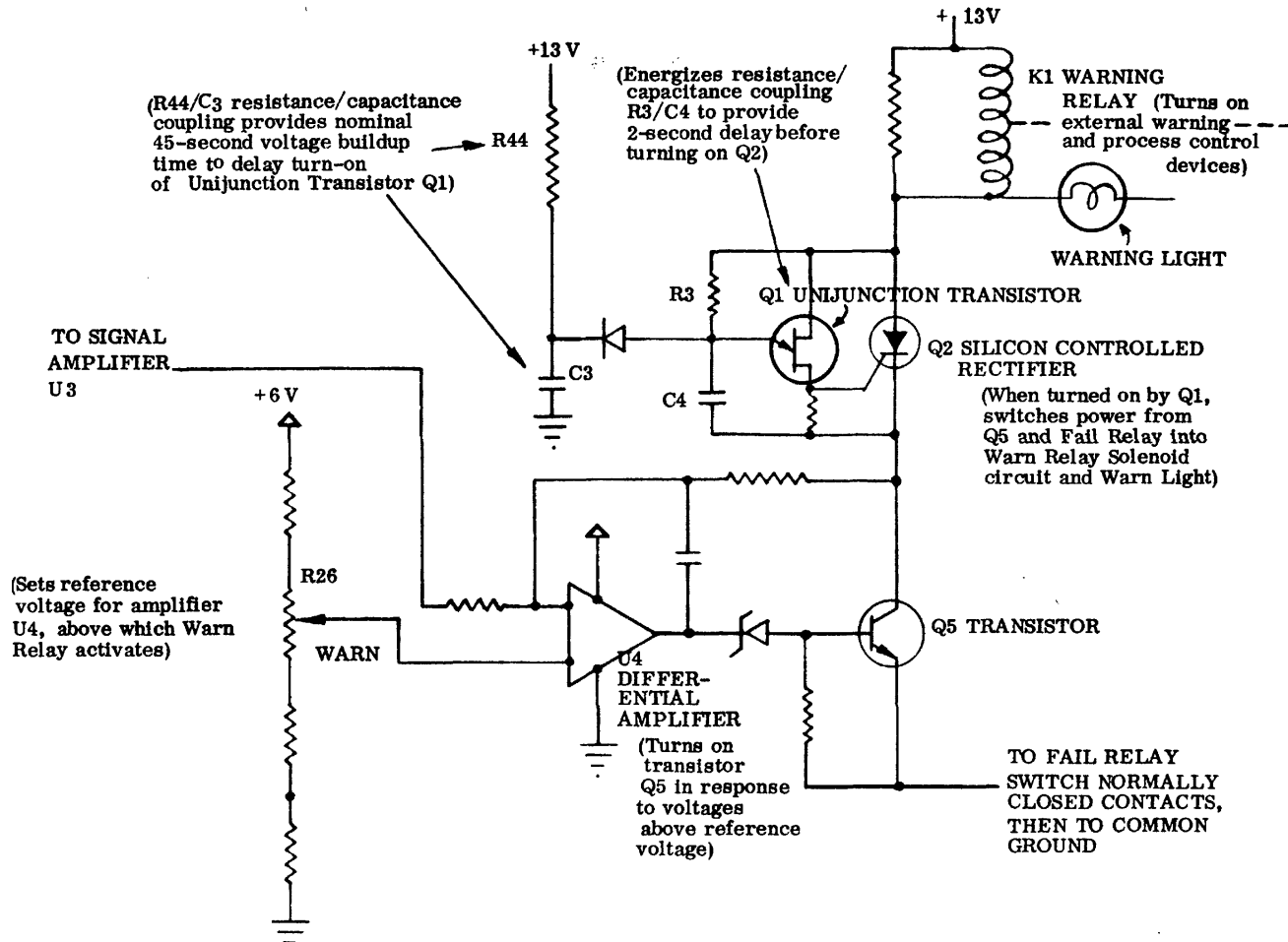

Figure 1-10. CD800/830 Warning Circuitry Schematic Diagram (typical also for Alarm circuitry)

1-3.1.5 **Alarm Circuit.** (Figure 1-10) The alarm circuit is identical to the warning circuit described above except that the reference voltage representing the level at which the alarm circuit operates is set with ALARM potentiometer R28 and compared in amplifier U5 for CD800/830, or R41 and U3 for CD802/832. Signals over reference level turn on transistor Q6 for CD800/830 or Q3/Q4 for CD802/832 to send power from the fail relay through the alarm relay and front panel red ALARM light. The alarm potentiometer (R28 for CD800/830 or R41 for CD802/832) is normally set to provide a reference voltage equivalent to 40-percent L. E. L. Once tripped, the warning and alarm relays remain in the energized state until the ALARM RESET pushbutton is depressed to reopen the relay latching circuit.

1-3.1.6 **Delay Circuits.** (Figures 1-10, 1-11)

NOTE:

TO PROTECT AGAINST TRANSIENT VOLTAGE
IMBALANCES DURING WARMUP, DELAY CIRCUITRY
INHIBITS WARNING, ALARM, AND TEST RESPONSES FOR
FROM 15 to 45 SECONDS AFTER POWER IS APPLIED,
EVEN IF POWER INTERRUPTIONS HAVE BEEN BRIEF.

During the brief warmup period after power has been applied, circuit imbalances could generate false warning and alarm signals. Therefore a nominal 15-to-45-second delay circuit is provided to inhibit such signals until the proper operating temperature at the detector is reached. Further, two identical 2-second (nominal) delay circuits--one for the warning circuit (Figure 1-10, CD800/830; Figure 1-11, CD802/832), and the other for the alarm circuit (not shown)--act to inhibit transient pulses caused by any temporary circuit disturbances, so that only signals sustained beyond the brief period of delay are permitted to energize the warn and alarm relays.

For CD800/830 control modules, the nominal 45-second delay occurs between resistor R44 and capacitor C3. Capacitor C3 takes time to charge through R44, depriving the emitters of unijunction transistors Q1 and Q3 of positive forward-biased (turn-on) voltage. Q1 and Q3 therefore cannot trigger, in turn depriving silicon-controlled rectifiers Q2 and Q4 of positive bias voltages which would cause these rectifiers to conduct. Since warning and alarm signals must pass through Q2 and Q4 respectively to energize the warning or alarm relays, no warning or alarm signals can reach the relays until capacitor C3 is charged.

The CD802/832 15-to-25-second delay occurs between resistor R56 and capacitor C9, depriving silicon-controlled rectifier SR3 of bias, which causes transistors Q3, Q4, and Q5 to be nonconducting so that warning and alarm relays cannot be switched during the period of delay.

For CD800/830 control modules, after capacitor C3 is charged (and detector operating voltages have been reached), the further 2-second delay to block reactions to spurious pulses occurs between resistor R3 and capaci-

23-9617
7/1/76

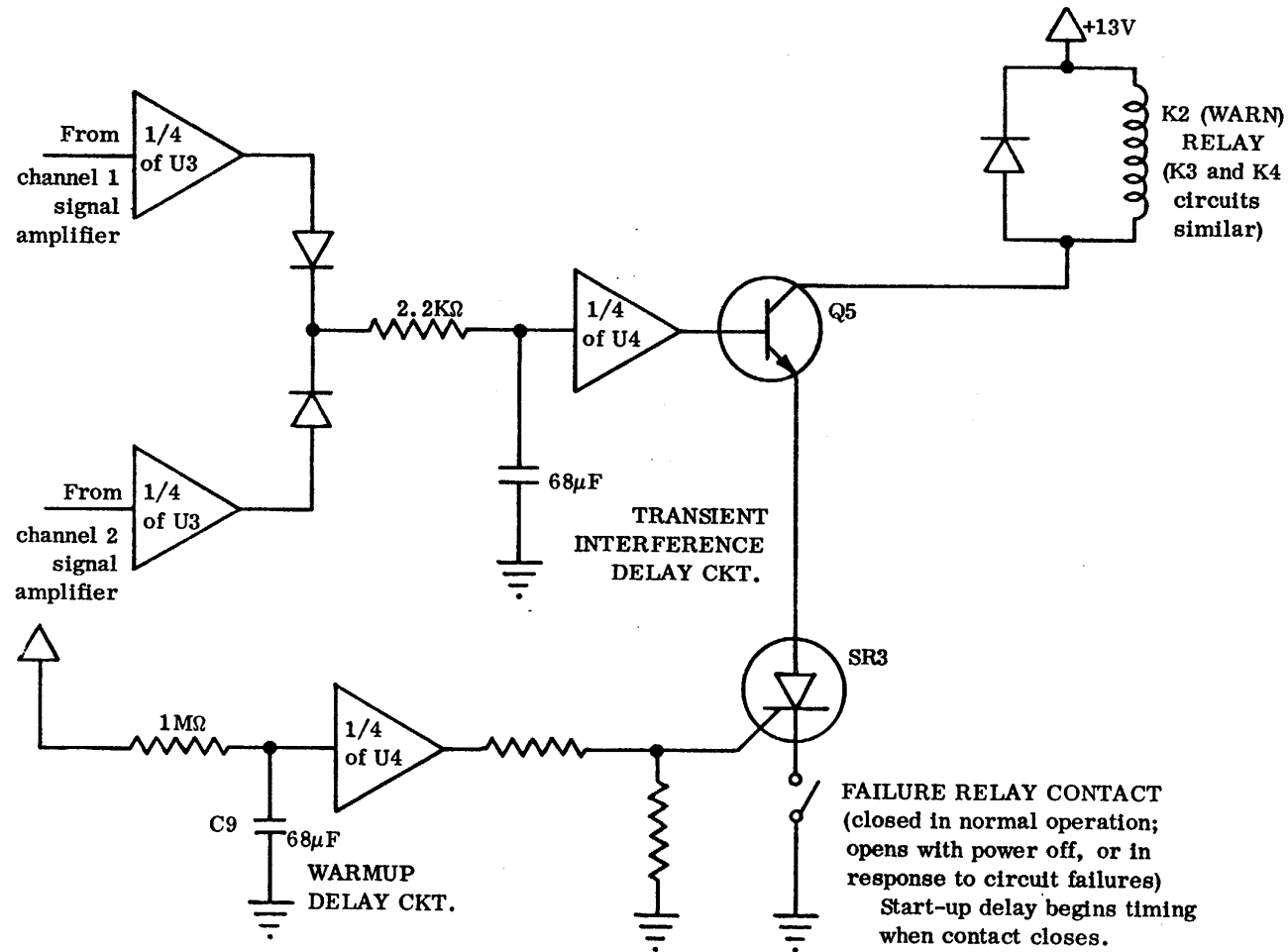

Figure 1-11. Time Delay Circuit CD802/832 Schematic Diagram

1-3.1.6 **Delay Circuits** (continued)

tor C4 for warning circuit signals, and between the equivalent alarm circuit resistor R6 and capacitor C5 for alarm circuit signals. Here the capacitors must build up enough charge to trigger unijunction transistors Q1 of the warning delay circuit and Q3 of the alarm delay circuit, which subsequently fire silicon-controlled rectifiers Q2 and Q4, whereupon the warning and alarm signals remaining after a nominal 2-second delay are released to activate the relays.

Circuits in CD802/832 control modules are similar to the above in philosophy, but employ four operational amplifiers in a common integrated circuit in the place of unijunction transistors and silicon-controller rectifiers.

1-3.1.7 **Fail Sensing and Relay Circuit.** (Figure 1-12) In normal operation, CD800/830 Fail relay K3 is energized to provide a closed contact through which warning and alarm circuits operate the warning and alarm relays if potentially dangerous gas conditions should occur. Operation of relay K3 is controlled through two transistors (Q7 and Q8) which switch off when certain circuit failures cause a lower-than normal voltage at Zener diode CR11 and at the bases of Q7 and Q8. When this happens, relay K3 is de-energized to switch off the warning and alarm circuitry, thus preventing false warnings and alarms until malfunctions in the foregoing circuits are corrected. Fault conditions most likely to drop the base voltage to turn off transistors Q7 and Q8 include detector sensor element failure, detector cable open or short circuit, improper setting of the VOLT adjust potentiometer R2, and a 10-percent-less-than-zero meter indication.

Fail relay K1 of the CD802/832 module operates similarly, depriving SR3, Q3, Q4, and Q5 of power during the failure mode.

1-3.1.8 **Alarm and Warning Reset Circuit.** To assure attention even to transitory warning and alarm gas conditions, the warning and alarm relays K1 and K2 of CD800/830 modules remain on once energized until manually reset. This happens because contacts 7 and 11 of relays K1 and K2 close in response to gas condition signals to provide direct paths to ground through diodes CR2 and CR3 and the normally closed ALARM RESET pushbutton switch. This latching action prevents both relays from de-energizing until the ALARM, RESET pushbutton is momentarily depressed. Conversely, depressing the pushbutton will not clear either the warning (K1) or the alarm (K2) relays if the warning and/or alarm circuits through these relays remain closed in response to gas conditions, since these circuits then energize the relays regardless of the open or closed state of the reset circuit. It follows that if the gas condition is below the high-alarm point but above the low-alarm point, only the high-alarm relay will be de-energized (reset), and the warning will remain.

23-9617
7/1/76

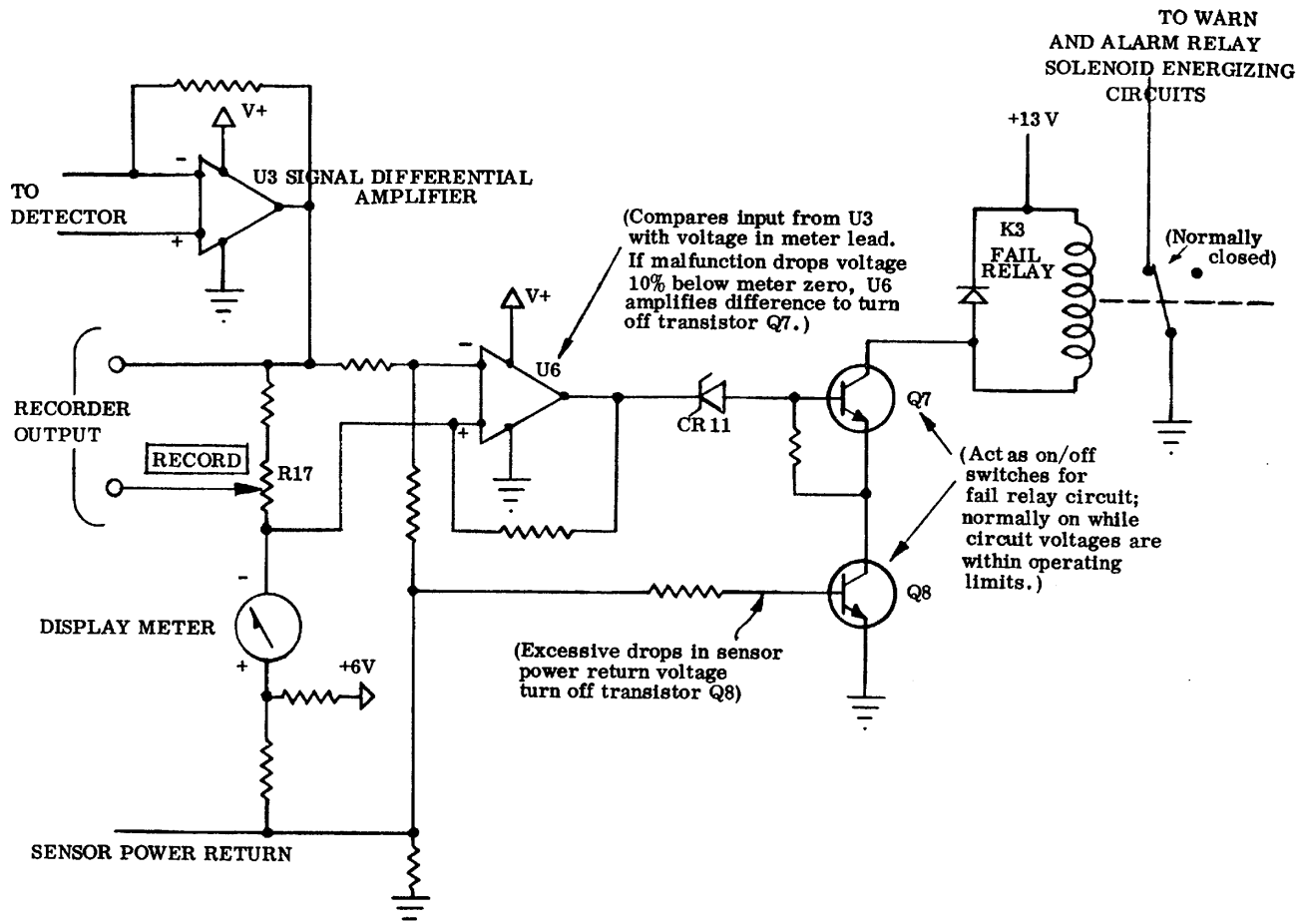

Figure 1-12. Fail Circuit Schematic Diagram

1-3.1.8 Alarm and Warning Reset Circuits (continued)

CD802/832 relays K2, K3, and K4 latch and reset in the same way as K1 and K2 of the CD800/830 control modules.

Circuit modifications for remote resetting, or for automatic resetting of warning and alarm relays as alarm conditions are cleared may be accomplished, if desired, during or after the installation of a system. (See Subsection 2-7.) A common reset button for several modules may be provided, in which case individual reset switches would not be incorporated in the system. Kits for conversion to common reset are available for systems with standard individual control module reset connections.

1-3.1.9 Display Meter. The display meter, located on the front panel of the control module, continuously indicates gas-to-air mixtures at the remote detect- or in terms of percentage of the lower explosive limit. With fresh air at the detector, the indicator reads zero. But catalytic oxidation of gas on the detector sensor produces unequal outputs from the two halves of the detector circuit, which causes a differential amplifier (U3 for CD800/830; U1 for CD802/832) in the control unit to amplify the difference and produce a proportionate current flow through the indicating meter (Figure 1-12).

The CD802/832 module meter responds either to the channel selected by the setting of the channel selector control, or, if the control is set to AUTO, to the channel with the strongest signal.

In addition to the mechanical adjustment-to-zero screw on the meter front, two electrical adjustments prepare the meter for proper indication of gas air mixtures. A ZERO potentiometer (CD800/830: R24; CD802/832: R9, R13) screw adjustment (Figures 1-4, 1-5, 1-9) serves to balance the input voltage to amplifier U3 (with detector in fresh-air or nitrogen-inerted condition for setting), to assure that the output signal fed to the meter is zero. After the indicator has thus been set to zero, a GAIN potentiometer (CD800/830: R10; CD802/832: R22) screw adjustment (Figures 1-4, 1-5, 1-9) provides the amount of amplification gain required to drive the indicator needle full-scale in the presence of a 100-percent L. E. L. gas-air mix at the detector. Because each combustible gas has its own rate of heat energy release upon oxidation, the GAIN adjustment must be set with respect to the kind or kinds of gas to be monitored.

1-3.1.10 Relay External Circuits. (Figures 1-13, 1-14) Solenoid operated contacts for controlling external lamps, buzzers, horns, fans, sprinklers, door closers, etc., are provided by control unit relays K1, K2, and K3 for all models, and an additional relay K4 for CD802/832 dual-channel models. Warning relay K1 and alarm relay K2 of CD800/830 models, and warning relay K2 of CD- 802/832 models each have two isolated normally open contacts and two

23-9617
7/1/76

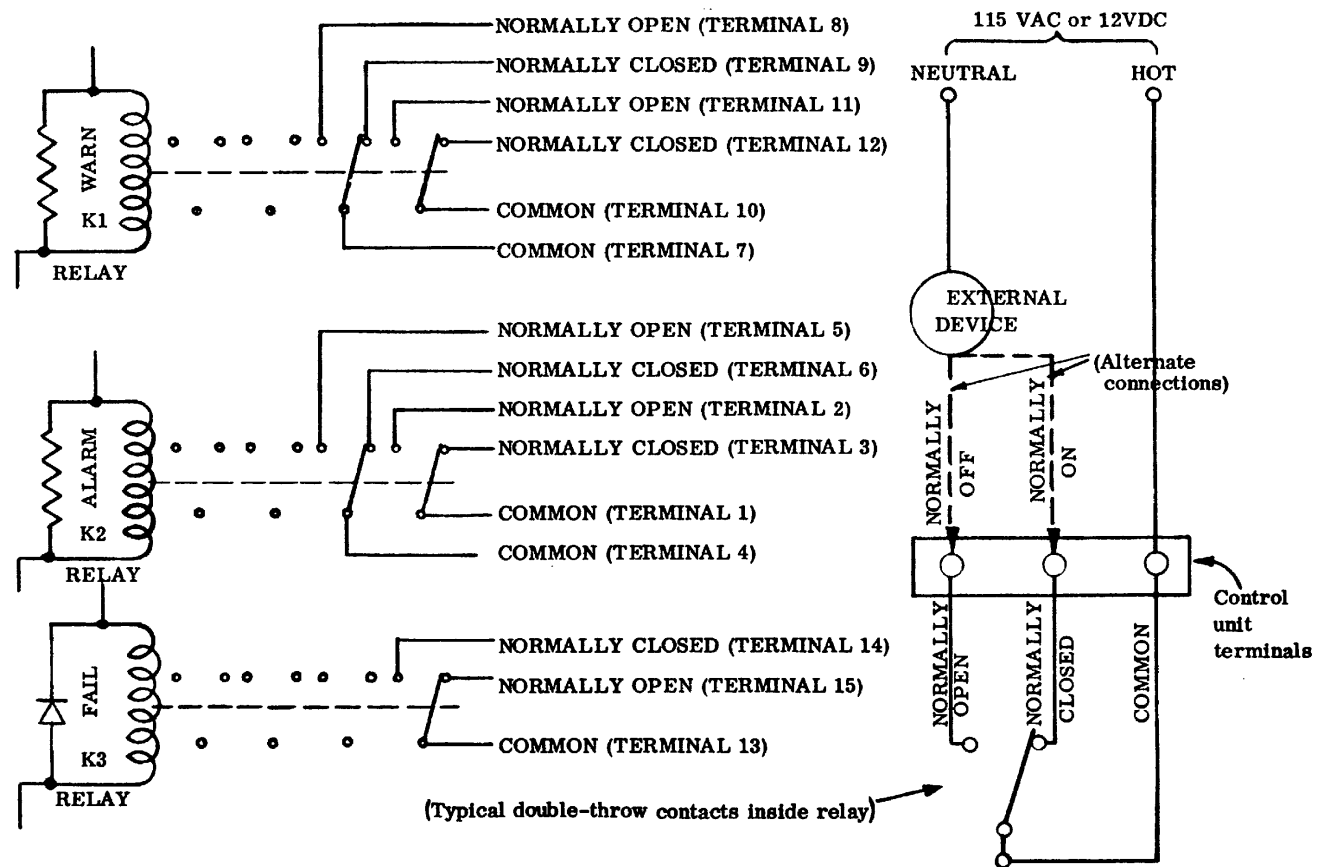

Figure 1-13. CD800/830 Relay External Circuits and Typical External Connections

(See Figure 1-13 for typical relay-to-external-device connections.)

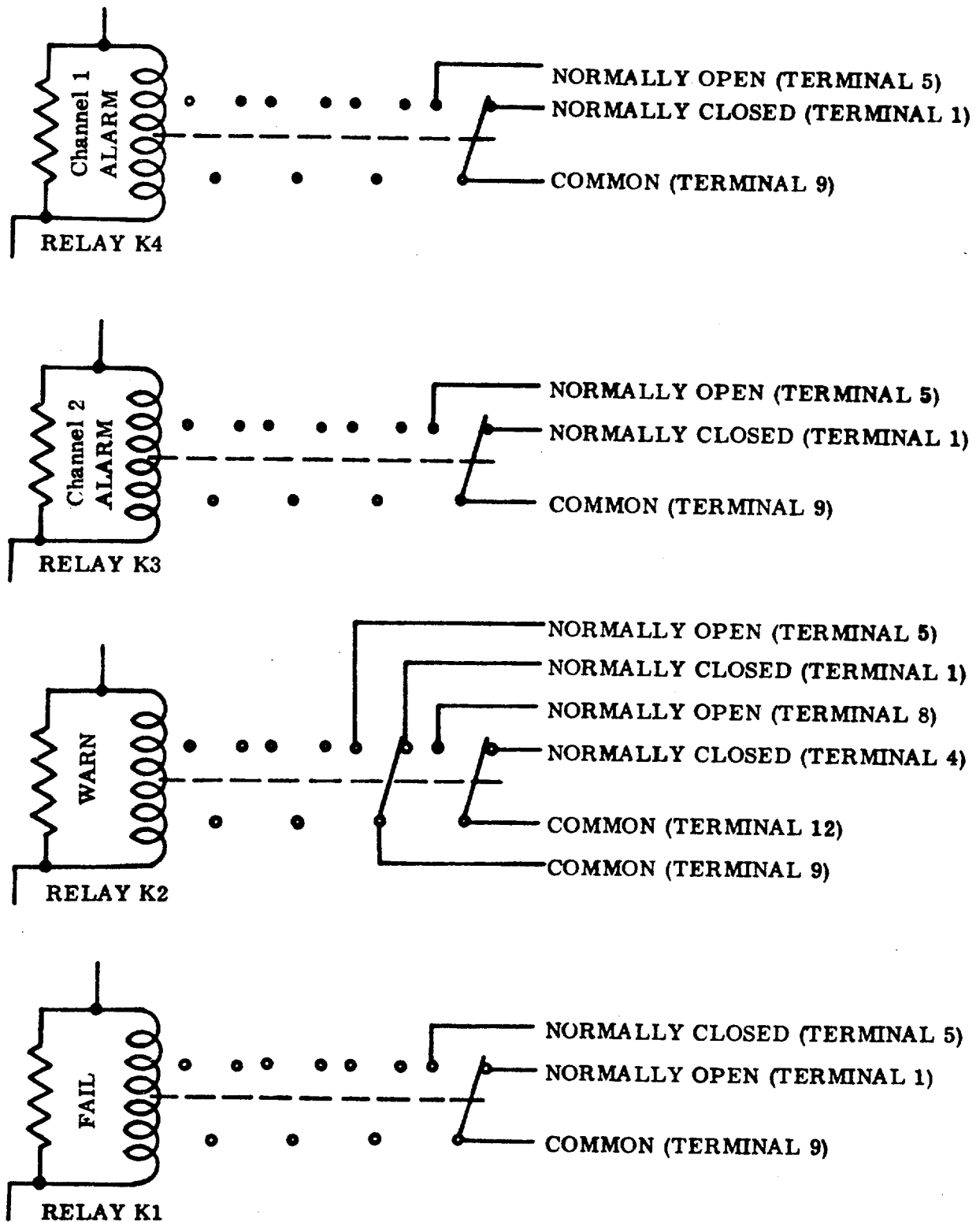

Figure 1-14. CD802/832 Relay Contacts Available for External Switching

1-3.1.10 **Relay External Circuits** (continued)

normally closed contacts (i.e. double-pole, double-throw) wired to terminals to which external devices may be connected. Fail relay K3 of CD800/830 models and K1 (Fail), K3 and K4 (Alarm) relays of CD802/832 models provide one normally open and one normally closed contact to which a remote indicating lamp, buzzer, or other device may be connected.

Relay switching contacts tolerate currents of up to 3 amperes (noninductive). For inductive loads, derate contacts to 1.5 amperes maximum. Devices requiring currents that exceed 3 amperes noninductive load or 1.5 amperes inductive load must be controlled by heavier external relays, which may be switched by the relays contained in the control module.

1-3.2 **CONTROL UNIT MODELS AND MODULAR CONFIGURATIONS**. CD800/830 and CD802/832 control units and modules are available in the following model configurations. CD800 and CD830 models contain circuit boards designed to monitor single points. CD802 and CD832 models contain printed circuit boards indicators, adjusters, and controls to monitor two discrete points per module.

1-3.2.1 **Series 800 or 802 single-unit configurations** (Figure 1-15):

CD800P, CD80OPF, CD802P, CD802PF: Vertical front panel; chassis enclosure. PF: with flexible cable; P: without flexible cable (extend- er card required to maintain connections to circuit-board-front-panel assembly when extended for adjustments and tests)

CD800W, CD802W: Horizontal front panel; fiberglass-reinforced polyester, wall-mounting cabinet; conduit hubs at either top or bottom

CD800X, CD802X: Circular front panel; explosion-proof cast aluminum housing for installation in hazardous areas

1-3.2.2. **Series 800 or 802 multi-module configurations** (Figure i-16): CD800/802 P or PF control units may be mounted together in any number at a central monitoring point. Five such units may be mounted side-by-side in a standard 19- inch instrument panel, or in cutouts in any panel or enclosure in the number desired. CD800 and 802 series control units provide an independent, integral power transformer for each unit, whereas CD830 and 832 series control modules operate from a rack-adapter-mounted power transformer common to up to six modules per rack.

23-9617
7/1/76

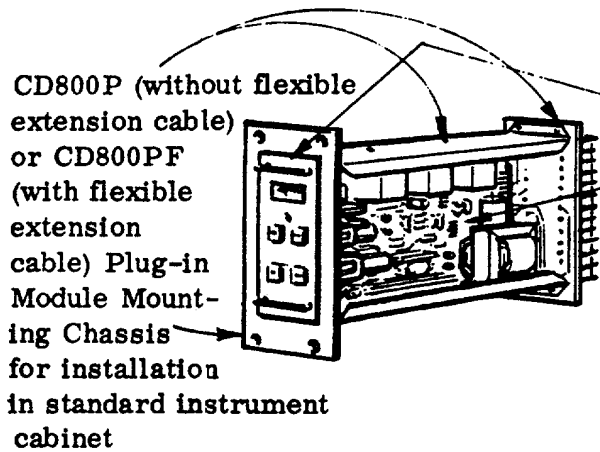

CD800P (without flexible extension cable) or CD800PF (with flexible extension cable) Plug-in Module Mounting Chassis for installation in standard instrument cabinet

(without cable: 0023-7318; with cable: 0023-7319)

Plug-in Control Module:

	CD830 single channel	CD832 dual channel
Unsealed relays	0023-7187	0051-7020
Without relays	0023-7188	0023-5029
Sealed relays	0023-7189	0051-7021

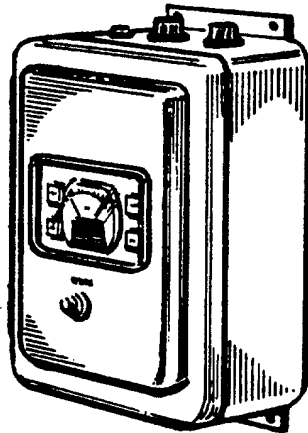

CD800W or CD802W Control Unit in Wall-mounting Fiberglass-reinforced Polyester Case for Installation in Nonhazardous Areas

CD800X or CD802X Control Unit in Wall-Mounting, Explosion-proof Cast Aluminum Cabinet for Hazardous Areas

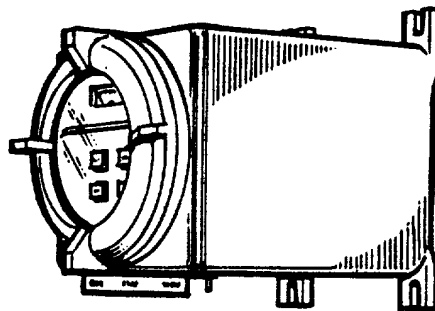
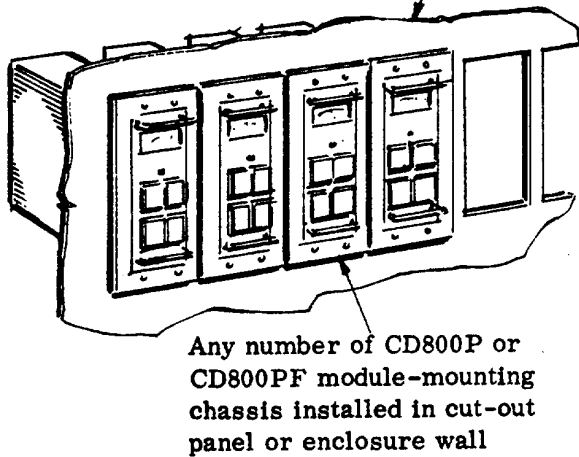
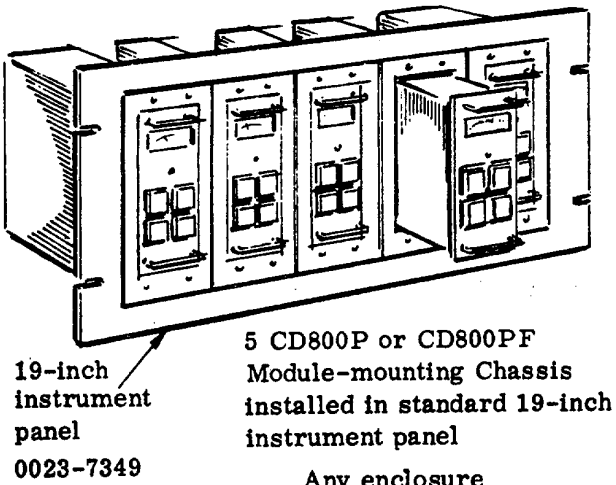
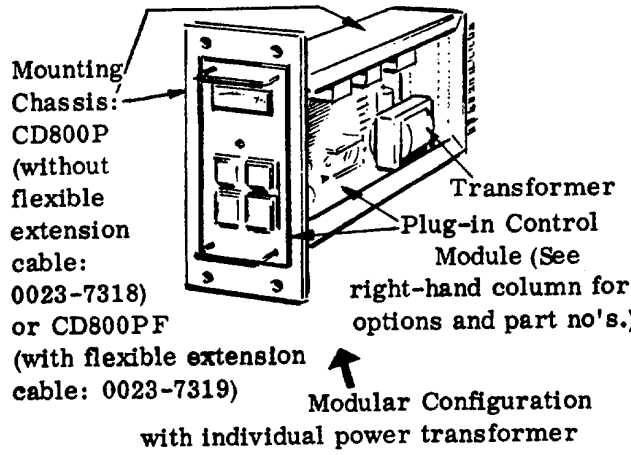
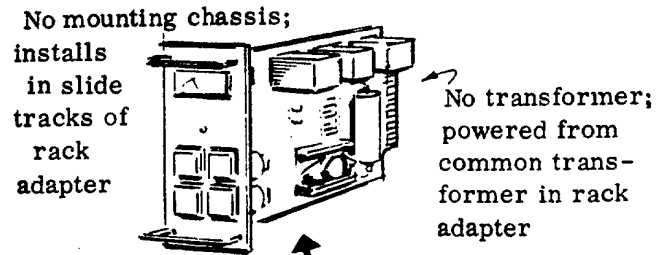

Figure 1-15. Series 800 and 802 Single-module Models

CD800P, CD800PF Multi-point Configuration :



CD830, CD832 Multi-module Configurations :



Plug-in Control Module (front panel & P.C.bd.):

	CD830 single channel	CD832 dual channel
Unsealed relays	0023-7187	0051-7020
Without relays	0023-7188	0023-5029
Sealed relays	0023-7189	0051-7021

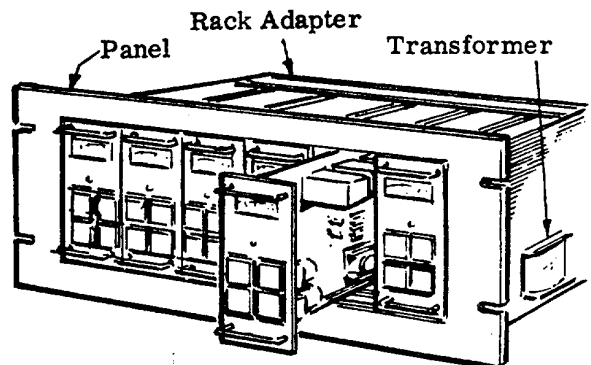
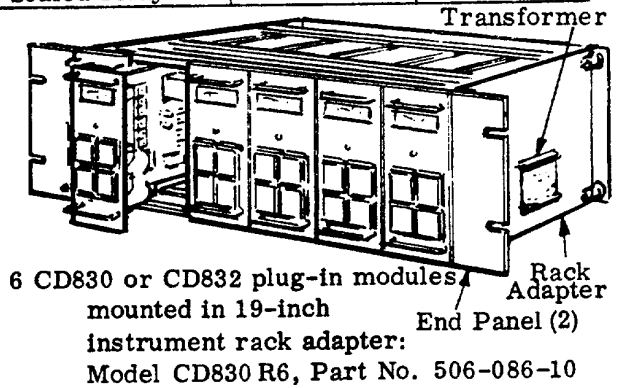

Figure 1-16. Multipoint Systems Configurations

23-9617
7/1/76

1-3.2 **CONTROL UNIT MODELS AND MODULAR CONFIGURATIONS** (continued)1-3.2.3 **Series 830 and 832 modular multipoint models:**

CD830R6, CD832R6:	Up to six modules installed in 19-inch rack adapter (Figure 1-16)
CD830P, CD832P:	Up to six modules installed in customer's 19-inch instrument panel (Figure 1-16)
CD830W4, CD832W4:	Up to four modules with vertical front panels, enclosed in wall-mounting cabinet (Figure 1-16)
CD830W8, CD832W8:	Up to eight modules enclosed in wall-mounting cabinet (Figure 1-17)
CD830F36, CD832F36:	Up to 36 individual modules assembled in floor-standing vertical cabinet. 830 system monitors up to 36 points; 832 system monitors up to 72 points. Combined systems are possible. (Figure 1-17)

All floor-standing cabinets contain forced ventilating equipment (Figure 1-18) suspended from the bottom instrument rack. An integral buzzer controlled by a thermal switch is provided to sound an alarm if fan failure or other circumstances allow temperatures in excess of 110 degrees F within the cabinet.

1-3.2.4 **Special Configurations:** Experience indicates that the configurations listed above meet most industrial requirements. Basic modules can be assembled in custom-designed configurations if standard assemblies do not satisfy special needs.

1-3.3 **INDICATORS, CONTROLS, AND ADJUSTERS.** Control module indicators, controls, and adjusters are as follows:

1-3.3.1 **Indicators** (Figures 1-19, 1-20, 1-21):

1. **Percent L. E. L. Indicating Meter:** Indicates concentrations of combustible gases or vapors in air as percentage of lower explosive limit. Located on control module front panel, all models.
2. **Pilot Light:** Glows to indicate power-on condition. Located in power on/off pushbutton lens for pre-1977 model CD830 modules, Figure 1-19, but on 1977 model is a green light-emitting diode near bottom left of front panel, Figure 5-1. For locations on front panels of CD800, CD802, and CD832, see Figures 1-20 and 1-21 (labeled POWER or PILOT).

23-9617
7/1/76

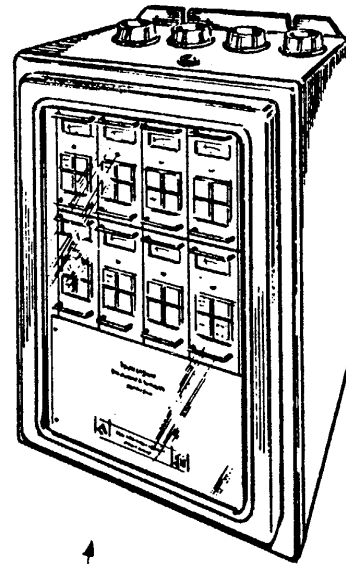

↑
CD830W, CD832W Wall Mounting Cabinet
with up to eight control modules
in rack

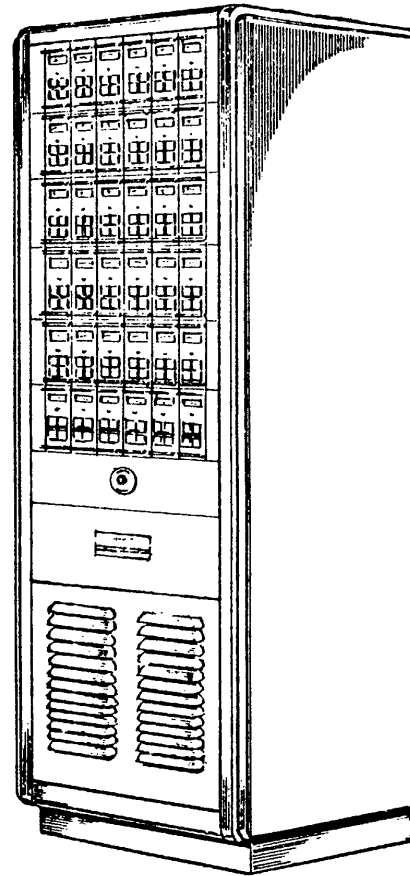

↗
CD830F,
CD832 F
Floor-standing
Cabinet with
up to 36
control modules
in standard
19-inch racks

Figure 1-17. CD830W, CD832W Wall Mounting Cabinet and CD830, CD832F Floor Standing Cabinet Multi-point Control Module Configurations

23-9617
7/1/76

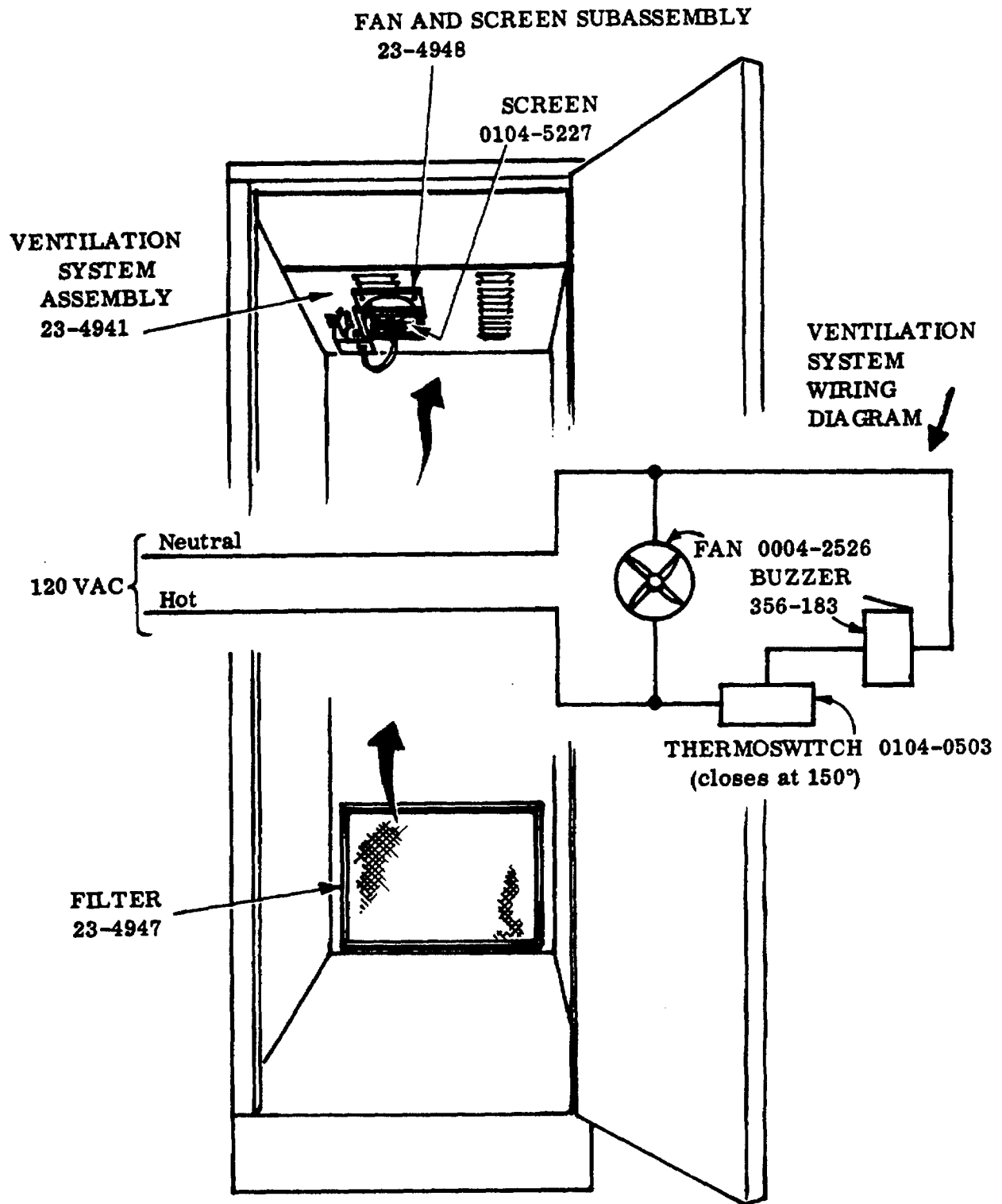

Figure 1-18. Forced Cooling Unit Assembly (120V) for Floor-standing Cabinet

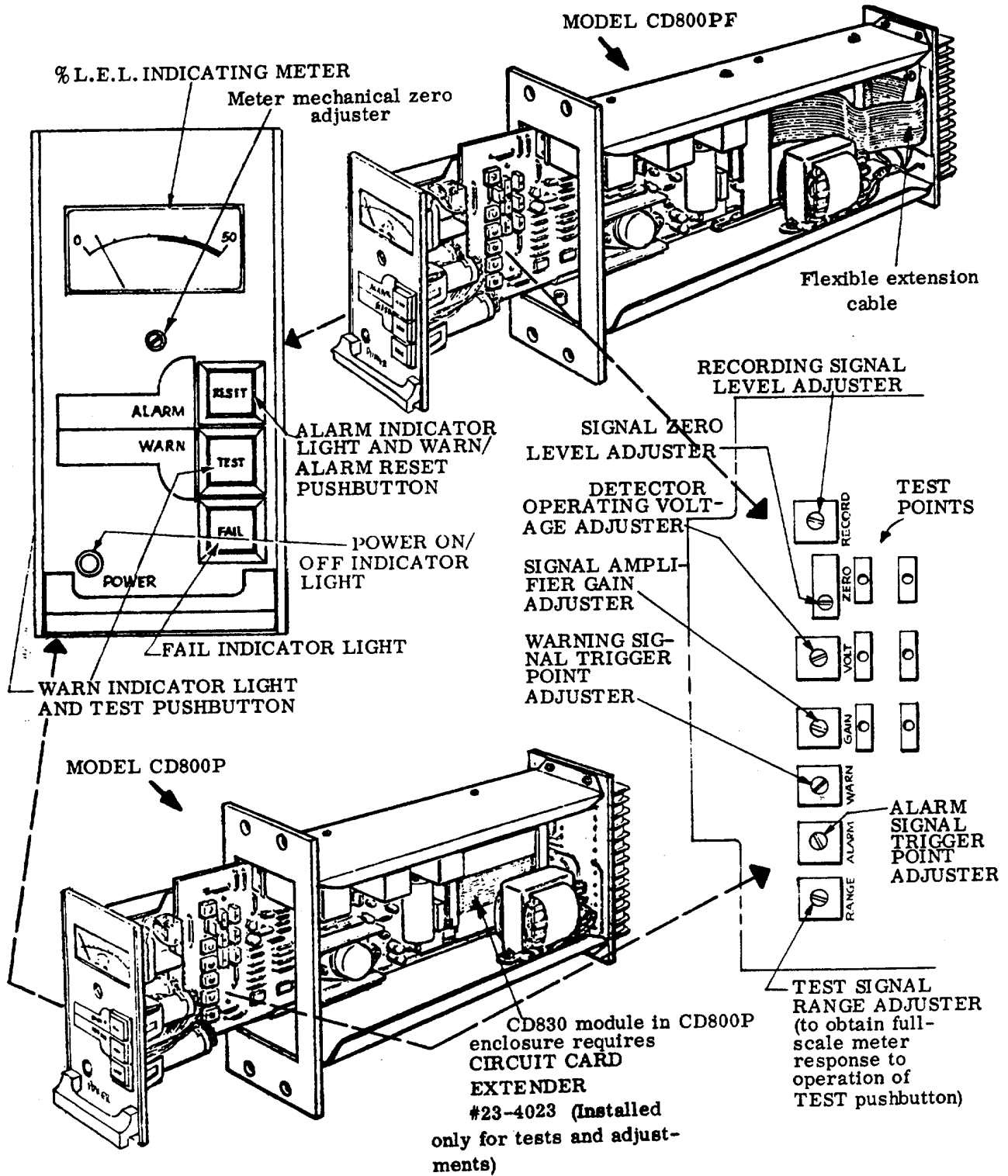
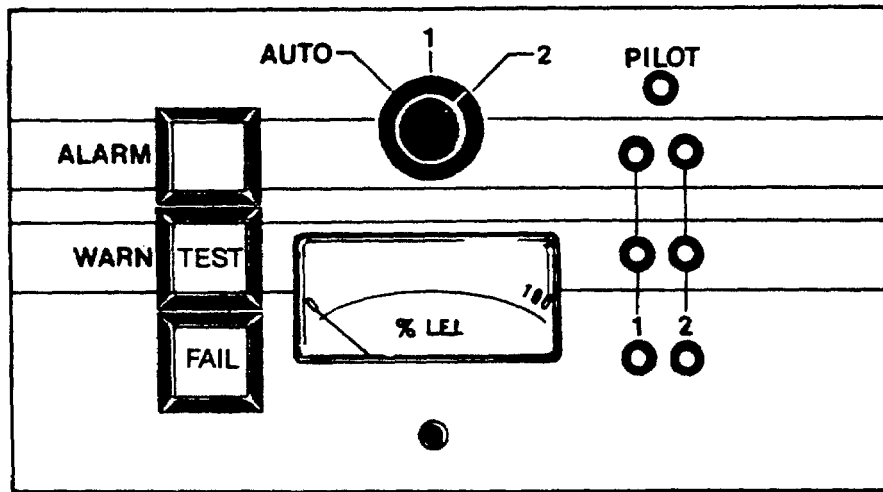
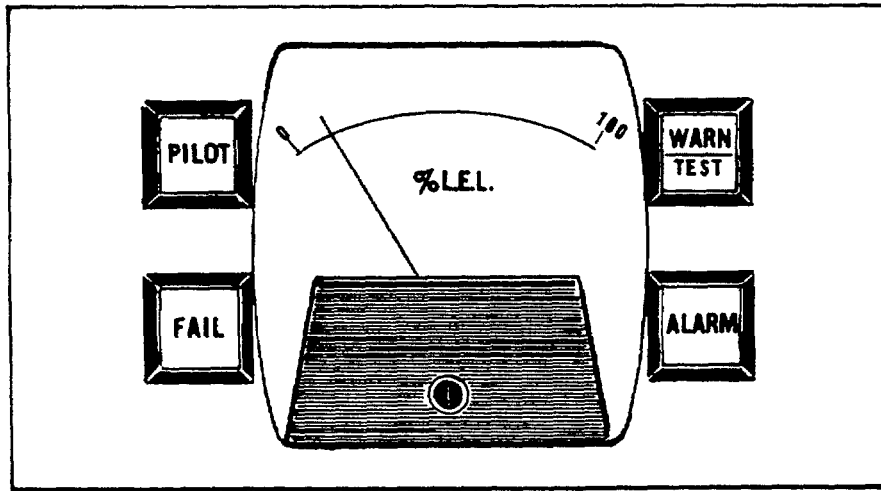

Figure 1-19. CD800P and CD800PF Mounting Enclosures with CD830 plug-in Control Modules, Showing Indicators, Controls, and Adjusters



CD802W (Dual Channel) Front Panel Configuration



CD800W (Single Channel) Front Panel Configuration

Figure 1-20. Front Panel Configurations, CD800W, CD802W Systems

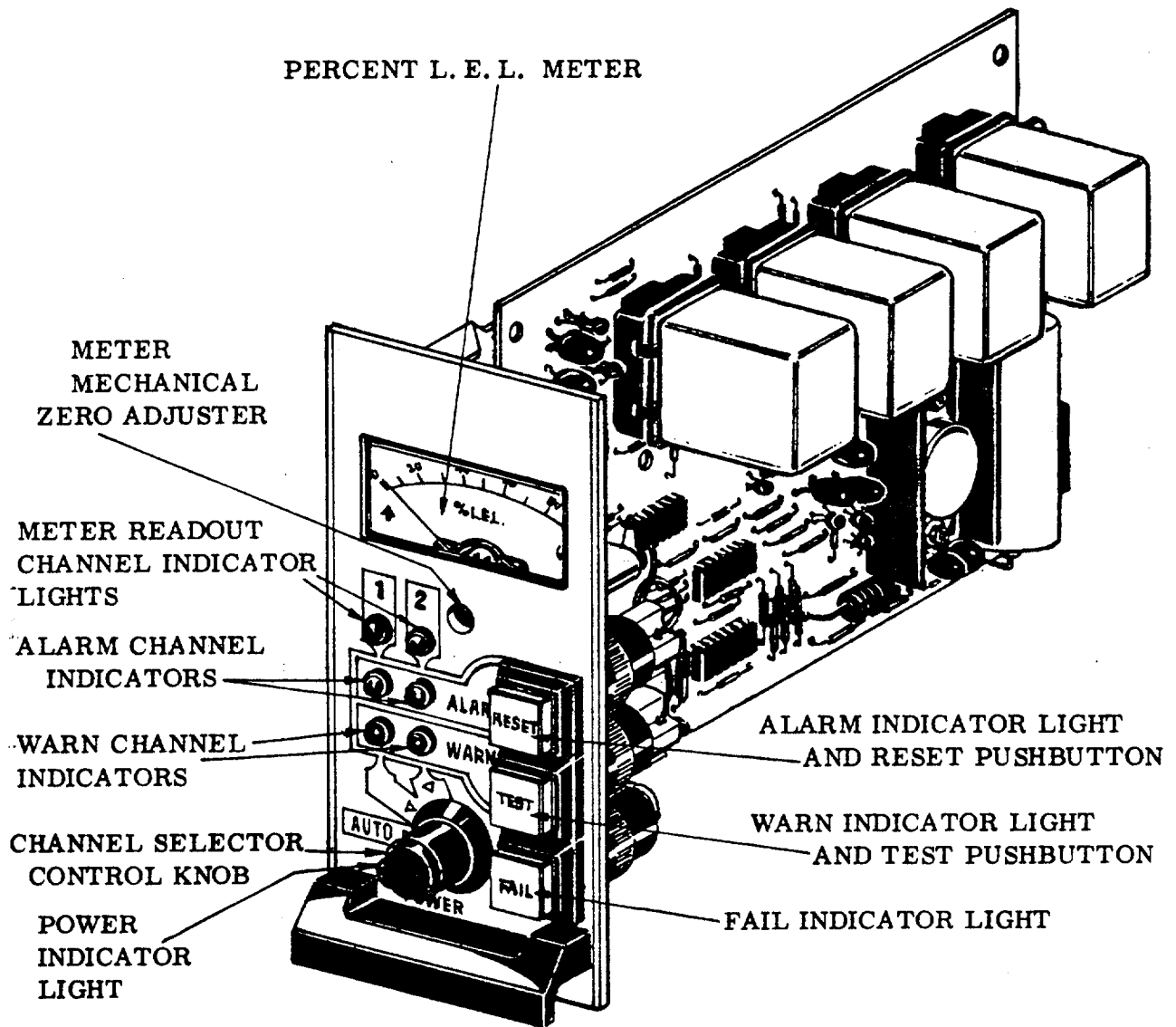

Figure 1-21. CD832 Controls and Indicators for Dual-Channel Systems

23-9617
7/1/76

1-3.3.1 **Indicators** (continued)

3. **Warn Light:** Glows to indicate warning level concentrations of combustible gases or vapors at a detector (Figures 1-19, 1-20, 1-21, and 5-1).
4. **Alarm Light:** Glows to indicate alarm level concentrations of combustible gases or vapors at a detector (Figures 1-19, 1-20, 1-21, and 5-1).
5. **Fail Light:** Glows to indicate detector circuitry malfunctions, such as open or shorted sensor filaments or power leads. Located on front panel of control module, all models.
6. **Meter-readout-channel Indicator Lights (CD802/832 modules):** Glow to indicate channel to which meter is responding (Figures 1-20, 1-21).
7. **Warn-channel Indicator Lights (CD802/832 modules):** Glow to indicate the channel from which a warning signal has come. Glow is steady until switched by RESET pushbutton, whereupon light goes off if no warning signal remains, or remains on if warning level concentration of gas persists at detector (Figures 1-20, 1-21).
8. **Alarm-channel Indicator Lights (CD802/832 modules):** Glow to indicate channel from which an alarm-level signal has come. Glow is steady until switched by RESET pushbutton, whereupon light goes off if no alarm signal remains, or continues to glow if alarm-level signal from detector persists (Figures 1-20, 1-21).

1-3.3.2 **Controls** (Figures 1-19, 1-20, 1-21, 5-1):

1. **Power On/Off Switch (pre-1977 model CD830, Figure 1-19):** A push-button switch operated to turn power to the instrument on or off. The pushbutton serves also as a lens cover for the PILOT light. (Power is supplied to other models by connecting a power cord or cable to an external power source.)
2. **TEST Pushbutton (all models):** Operated to apply a simulated gas signal to deflect Percent L. E. L. meter pointer full-scale, turn on warning and alarm lights, and trigger internal relays for control module operational tests.
3. **RESET Pushbutton (all models):** Operated to switch ("unlatch") internal relays triggered by warning or alarm signals from detector or test circuitry. Circuit logic is such that relays will not unlatch despite operation of the RESET switch while gas concentration at a detector is above the warning or alarm level.

1-3.3.2 **Controls** (continued)

4. **Channel Selector Switch (CD802/832 modules)**: Turned to AUTO mode: switches meter circuitry to respond to channel with strongest signal. Turned to channel 1 or channel 2 position: switches meter circuitry to respond to signal from selected channel. Alarm and warning circuits remain active on both channels despite setting of channel selector switch.

1-3.3.3 **Adjusters** (Figures 1-19, 1-22):

1. **VOLT Adjuster**: Potentiometer with adjustment screw; labeled VOLT on printed circuit board; turned to adjust operating voltage applied to detector(s) from the voltage regulating circuitry of the circuit board.
2. **ZERO Adjuster**: Potentiometer with adjustment screw; labeled ZERO on printed circuit board; turned to adjust signal voltage for zero meter reading with fresh air (containing no combustible gases or vapors) at the detector(s). The CD800/830 circuit board has one ZERO adjuster (Figure 1-19); the CD802/832 circuit board has two (one for each of the two independent signal channels, Figure 1-22).
3. **GAIN Adjuster**: Potentiometer with adjustment screw; labeled GAIN on printed circuit board; turned to adjust signal amplification for accurate percent L. E. L. meter readings of concentrations of specific gas or vapor to be monitored. Also turned to compensate for gradual depletion of catalyst in the expendable detector sensor and the consequent slowly diminishing response. The CD800/830 circuit board has one GAIN adjuster (Figure 1-19); the CD802. 832 circuit board has two (one for each of two independent signal channels, Figure 1-22).
4. **TEST Signal Range Adjuster**: Potentiometer with adjustment screw; labeled RANGE on the CD800/830 printed circuit board (Figure 1-19), and TEST on the CD802/832 circuit board (Figure 1-22). This adjuster is turned to obtain full-scale meter pointer deflection when the TEST pushbutton is pressed.
5. **WARN Signal Trigger Point Adjuster**: Potentiometer with adjustment screw; labeled WARN on printed circuit board (all models, Figure 1-19, 1-22). This adjuster is turned to set a reference voltage in a circuit that triggers the warning signal output circuitry when the gas signal rises to the warning reference voltage level.

23-9617
7/1/76

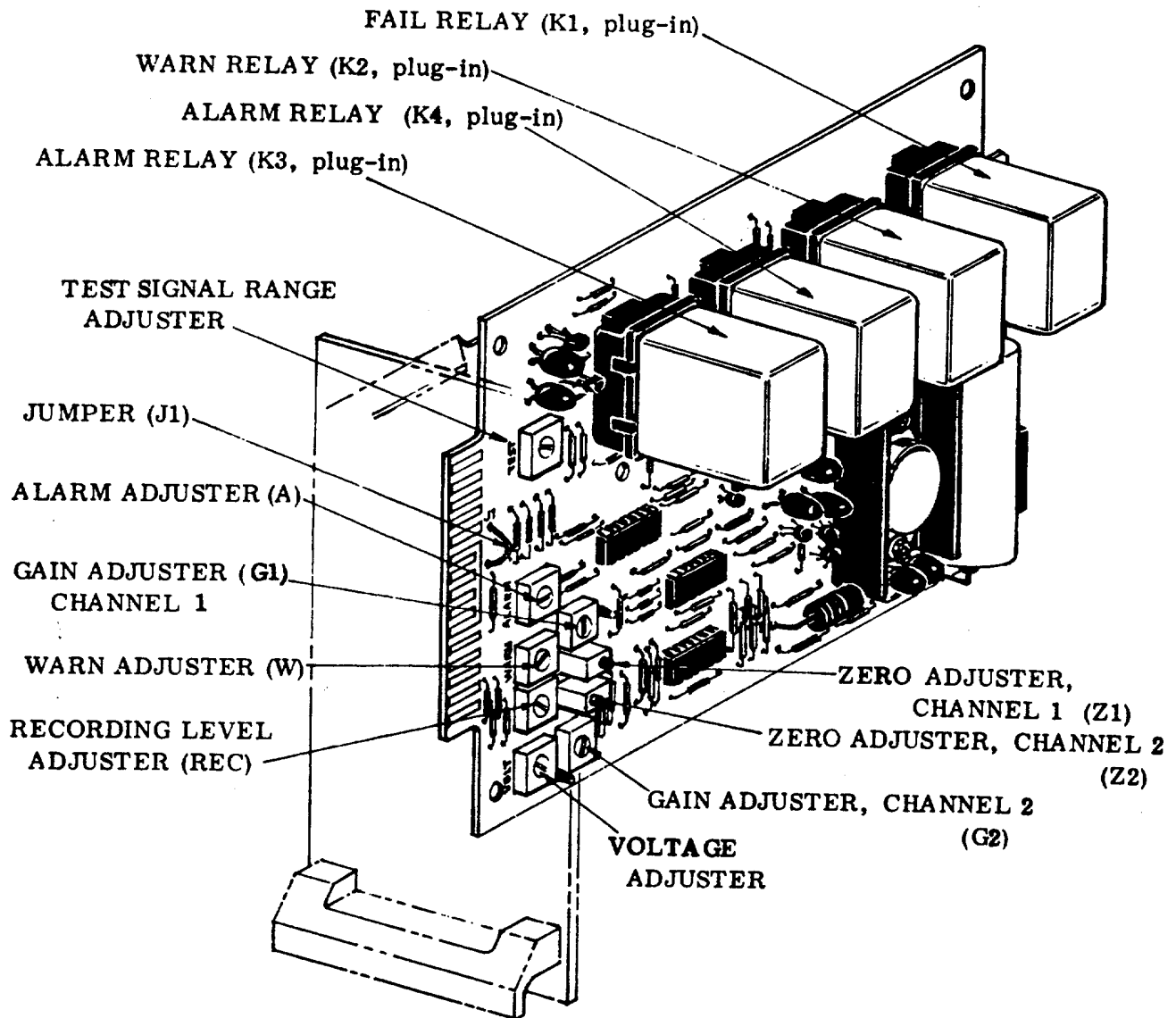

Figure 1-22. CD802/832 Circuit Board: Relays and Adjusters for Dual-channel Systems

23-9617
7/1/76

1-3.3.3 **Adjusters** (continued)

6. **ALARM Signal Trigger Point Adjuster**: Potentiometer with adjustment screw; labeled ALARM on printed circuit board (all models, Figures 1-19, 1-22). This adjuster is turned to set a reference voltage in a circuit that triggers the alarm signal output circuitry when the gas signal rises to the alarm reference voltage level.
7. **Recording Signal Level Adjuster**: Potentiometer with adjustment screw; labeled RECORD on CD800/830 circuit board (Figure 1-19), and REC on CD802/832 circuit board (Figure 1-22). This adjuster is turned to set the recorder signal output to drive an optional external recorder to record values consistent with the percent L. E. L. meter readings. Like the percent L. E. L. meter, the recorder output will display either the channel with the higher output or the channel on which the channel selector switch is set.
8. **Meter Zero Mechanical Adjuster**: Screw adjuster under meter, all models, turned to set meter pointer to zero with instrument power off. This mechanical movement adjuster is not to be used as a substitute or compensation for electrical adjustments.

1-4 **EXTERNAL ACCESSORY DEVICES**

The following external accessory devices are manufactured or selected for use with the CD800/830 or CD802/832 basic system:

Audible Buzzer	356-183
115 VAC Explosion-proof Alarm Horn	356-215
115 VAC Weatherproof Alarm Horn	352-254
5 AMP, 120V, DPDT Standard Relay	361-251
5 AMP, 120V, DPDT Hermetically Sealed Relay	361-252

In addition to the above accessories available from the Bacharach Instrument Company, a wide variety of external devices such as fans, sprinklers, door-closers and process control mechanisms may be controlled by the basic system. Such devices may be connected directly to the control unit where resistive load current does not exceed 3 amperes at 115 VAC or 30 VDC. External devices with higher current ratings may be operated through an auxiliary power relay wired to the controlling unit.

23-9617
7/1/76

SECTION 2

INSTALLATION

To assure optimum gas monitoring efficiency and trouble-free operation, CD800/830 and CD802/832 Gas Alarm systems should be installed in accordance with the following procedures and specifications, based on engineering design considerations and experience.

2-1 LOCATION OF DETECTORS

Detectors should be located at sites where the presence and concentrations of combustible gases must be detected with respect to the following conditions (Figures 2-1 and 2-2):

1. Air currents: Detectors should be located where prevailing air currents contain the fullest possible concentrations of escaping gas.
2. Relative weight of gas: Detectors should be located near the floor for heavier-than-air gases or vapors from flammable liquid spills, and near the ceiling or roof to detect lighter-than-air gases such as hydrogen and natural gas. Vapors from all liquids are heavier than air.
3. Dispersion of gas: Though detectors should not be far removed from any potential source of escaping gas, liquids of low volatility especially demand location of the detector in the immediate vicinity of the escaping vapor, since a slow rate of dispersion could result in falsely low sample readings at short distances from the site.
4. Heat: Standard diffusion type detectors are designed to operate within a range of from -30° to +200°F, but must be located away from areas outside this range. Special high-temperature detectors are available, such as #0050-7005 (for temperatures to 340° F) or High Temperature Probe #0023-7363 with #0023-7338 element, for temperatures to 600° F. Since diffusion sampling is not feasible for detectors located remotely from the area to be monitored, the #0023-4017 remote sample drawing detector assembly is recommended for such applications. Practical sampling line lengths of 75 to 100 feet are possible, using 1/4" OD tubing.

CAUTION:

The #0023-4017 detector assembly must not be used to draw flammable liquid vapors having flash points higher than the expected ambient temperature from atmospheres at elevated temperatures. On cooling to ambient temperatures, the vapors of such samples may condense in the sample tubing before reaching the reaction chamber. For high flash vapors, Bacharach's special Heated Sample Drawing detector assembly should be used. Consult factory for such applications.

23-9617
7/1/76

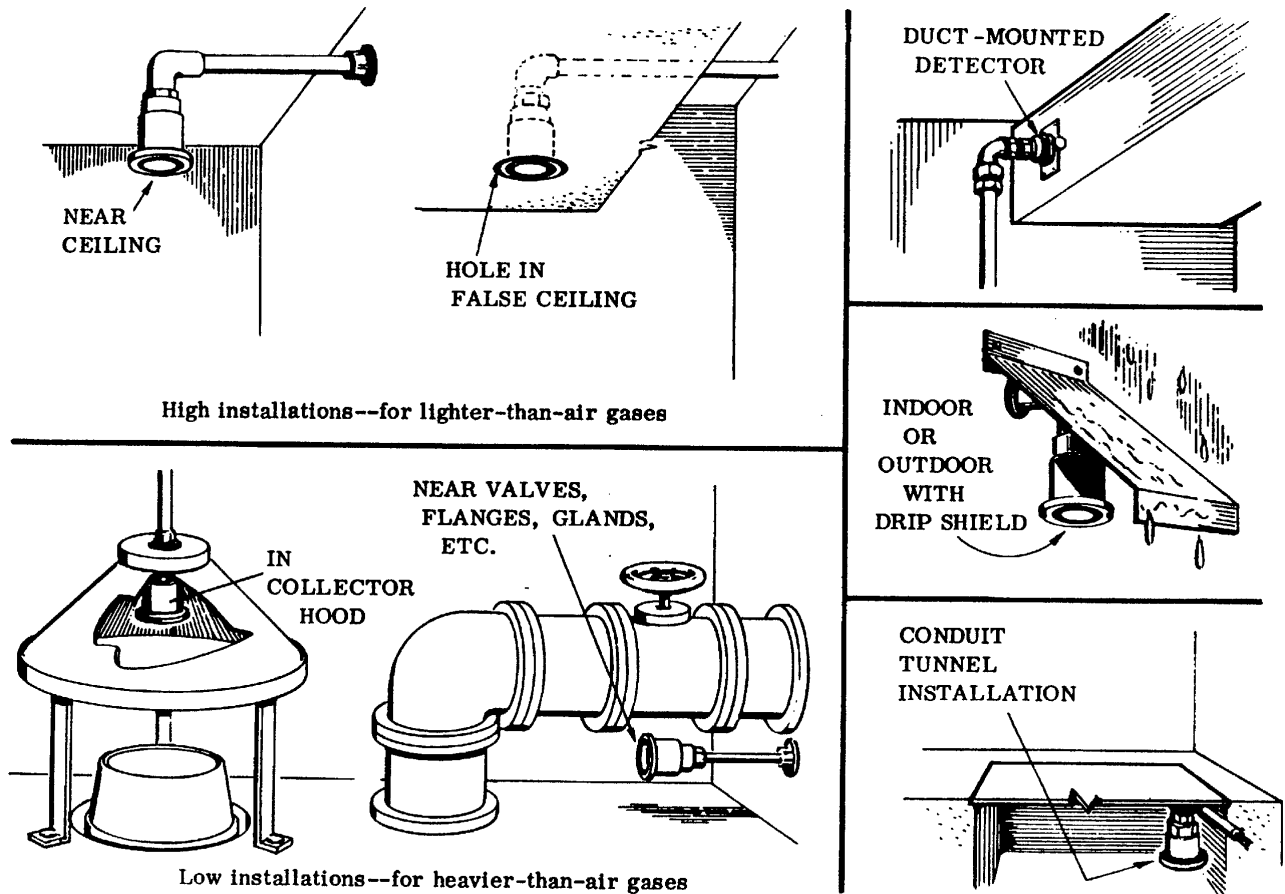

Figure 2-1. Typical Location Points for Detectors

23-9617
7/1/76

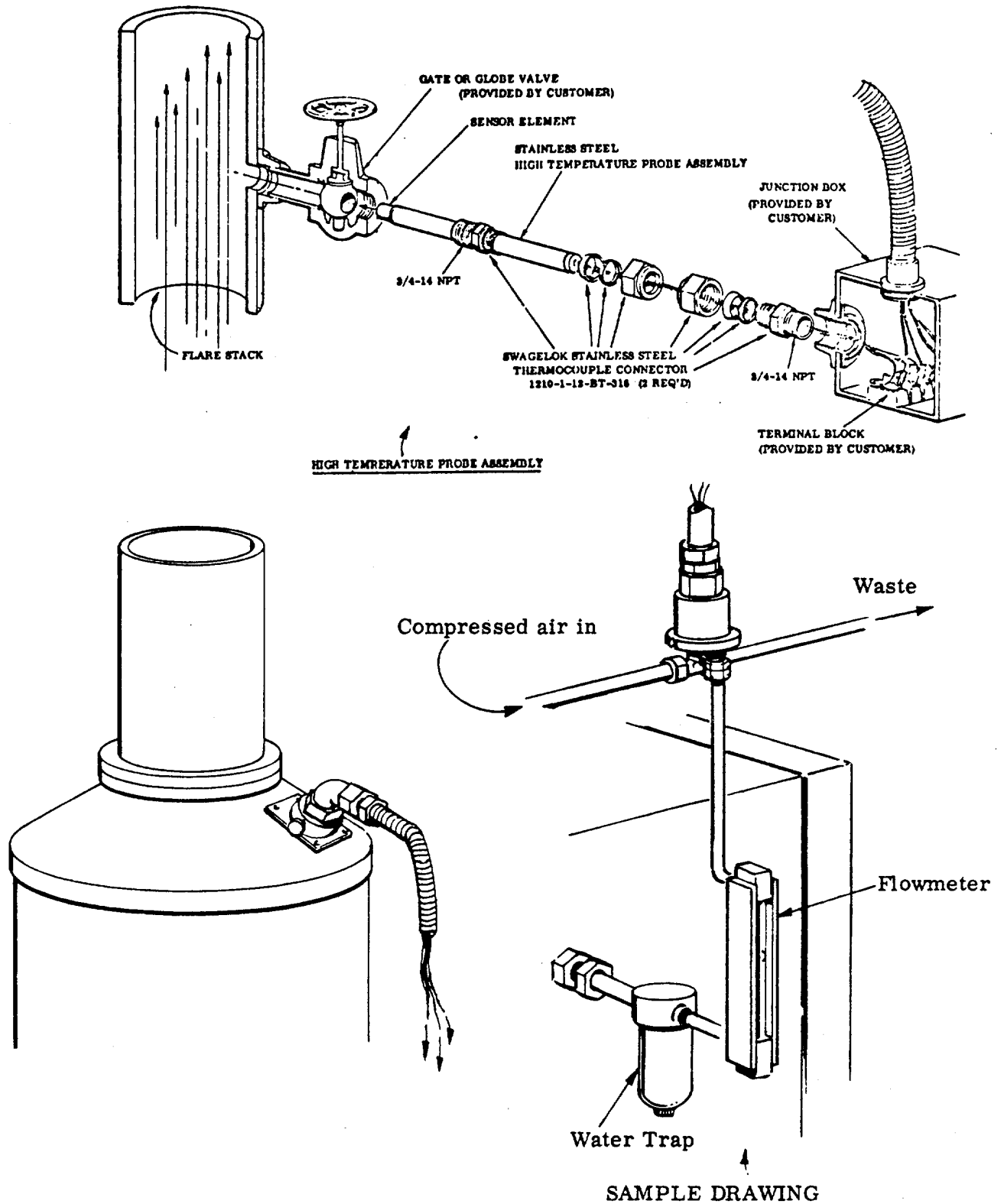

Figure 2-2. Typical Through-Bulkhead Installations

23-9617
7/1/76

2-1 **LOCATION OF DETECTORS**

5. **Corrosive gases:** The destructive effects of corrosive gases may in some cases be minimized by locating the detector in a protected area and conditioning samples to reduce corrosiveness as they are drawn by vacuum to the detectors. Where moisture or liquid-type line filters are used, special care should be taken during installation to ensure that such devices are accessible for periodic servicing if required.
6. **Water, moisture, dust, and dirt:** Detectors should be mounted where water cannot enter and fill the housing to prevent exposure of the sensor element to air. Likewise, exposure to moisture, dust, and dirt should be minimized by locating detectors away from points where large amounts of such contaminants fill the air. Small overhanging or surrounding covers may be devised to protect detectors from the intrusions of dust and dirt in severe environments. A special moisture-proof detector (Model #0023-7317) should be installed where extreme humidity presents a special problem.

2-2 **LOCATION OF CONTROL UNITS**

If possible, locate control modules or enclosures in dry, clean, nonhazardous areas; ideally, in plant engineer's control room or other place where temperature, moisture, corrosive and explosive atmospheres, or other conditions will not endanger personnel or hinder the maintenance and operation of the equipment. If a source of compressed air is readily available for cabinet purging, W- series (wall-mount) enclosures may be located in Division 2 hazardous locations. * The CD800X (explosion-proof housing) may be safely located in Division 1, Groups B, C, and D, hazardous environments. In any case, length of wire should be considered with respect to installation cost. If fans, sprinklers, door closers, ovens, or other devices are to be controlled by the control module relays, the length of the control wiring for these purposes should also be considered.

2-3 **LOCATION OF WARNING DEVICES**

Remote annunciators such as bells, buzzers, lamps, etc., should be located where they may be readily seen or heard by personnel responsible for remedial actions, and preferably should be near the control cabinet where the nature of the condition and the appropriate response may be more readily perceived. Alarm devices should also be located in or near detectors to alert all personnel in the vicinity of an alarm. Audible alarms should be installed not less than one foot from the ceiling and, wherever possible, not less than eight feet from the floor.

2-4 **CONTROL MODULE INSTALLATION**

Control modules and control module assemblies are installed in accordance with

- Where permitted by governing code enforcement authorities.

23-9617
7/1/76

2-4 **CONTROL MODULE INSTALLATION** (continued)

the structural requirements of a selected configuration. Standard module configurations are usually installed in the following ways:

- 2-4.1 **CD800P** (one control- module in metal case with rectangular front panel surrounding module front panel): Install in customer's instrument panel by means of four #10 mounting screws through case front panel (Figure 2-3). Cutout in panel to receive module should be 3.30 x 6 inches.
- 2-4.2 **CD800W, CD802W** single module, fiberglass, wall mounting cabinet: Mount on wall at selected location by means of four 1/4" screws through holes in rear top and bottom flanges on cabinet. Connect conduits to conduit hubs on top or bottom of cabinet (Figure 2-4). For cabinets ordered without conduit hub holes, install snap-in standoffs as shown in Figure 2-5 for on-site installation of hubs at top or bottom of cabinet. Install grounding hub and groundwire.
- 2-4.3 **CD800X** single module, explosion-proof, wall mounting, cast aluminum housing: Mount on wall at selected location by means of four 3/8" screws or bolts through four mounting-lug slots on rear of housing. Connect 1-inch conduit to tapped conduit fitting hole in bottom of housing (Figure 2-6).
- 2-4.4 **CD830W4/W8, CD832W4/W8** wall mounting, 14-gauge steel cabinet with 4 to 8 control units: Mount on wall at selected location by means of four 1/4" screws or bolts through four slots in mounting flanges at rear top and bottom of cabinet. Connect 1-1/2 inch conduits as required to conduit fitting on top and bottom of cabinet. To prevent severe corrosion, or to reduce a hazardous area classification, wall-mounting cabinets can be positive-pressure ventilated. (Ref. NFPA No. 496-1967 Standard for purged enclosures for electrical equipment in hazardous locations.) Connect 1/4-inch air-purge pipe to air-purge fitting on top of cabinet if required (Figure 2-7).
- 2-4.5 **CD830R6, CD832R6** 19-inch rack adapter with 6 control units: Install rack adapter in standard rack cabinet, using four 1/4" screw through slots in left and right end panels (Figure 2-8).
- 2-4.6 **CD830P6, CD832P6** 19-inch panel with 6 control units, for mounting in customer's panel: Cut 17-1/2 x 5-1/2-inch rectangular hole in panel and drill and tap four screw holes, located in accordance with dimensions shown in Figure 2-8. Insert instrument rack adapter and panel assembly through cutout in panel and fasten to front panel with four 1/4" screws.
- 2-4.7 **CD830F, CD832F** (up to 36 control units in Emcor No. FR126A instrument cabinet): Procedures for installation of the CD830F cabinet (with control units preinstalled) include placement of the cabinet where desired and the installation of conduits for power and detector cables. Conduits may enter the cabinet through either top or bottom of enclosure. Cabinet dimensions are shown in Figure 2-9.

23-9617
5/9/80

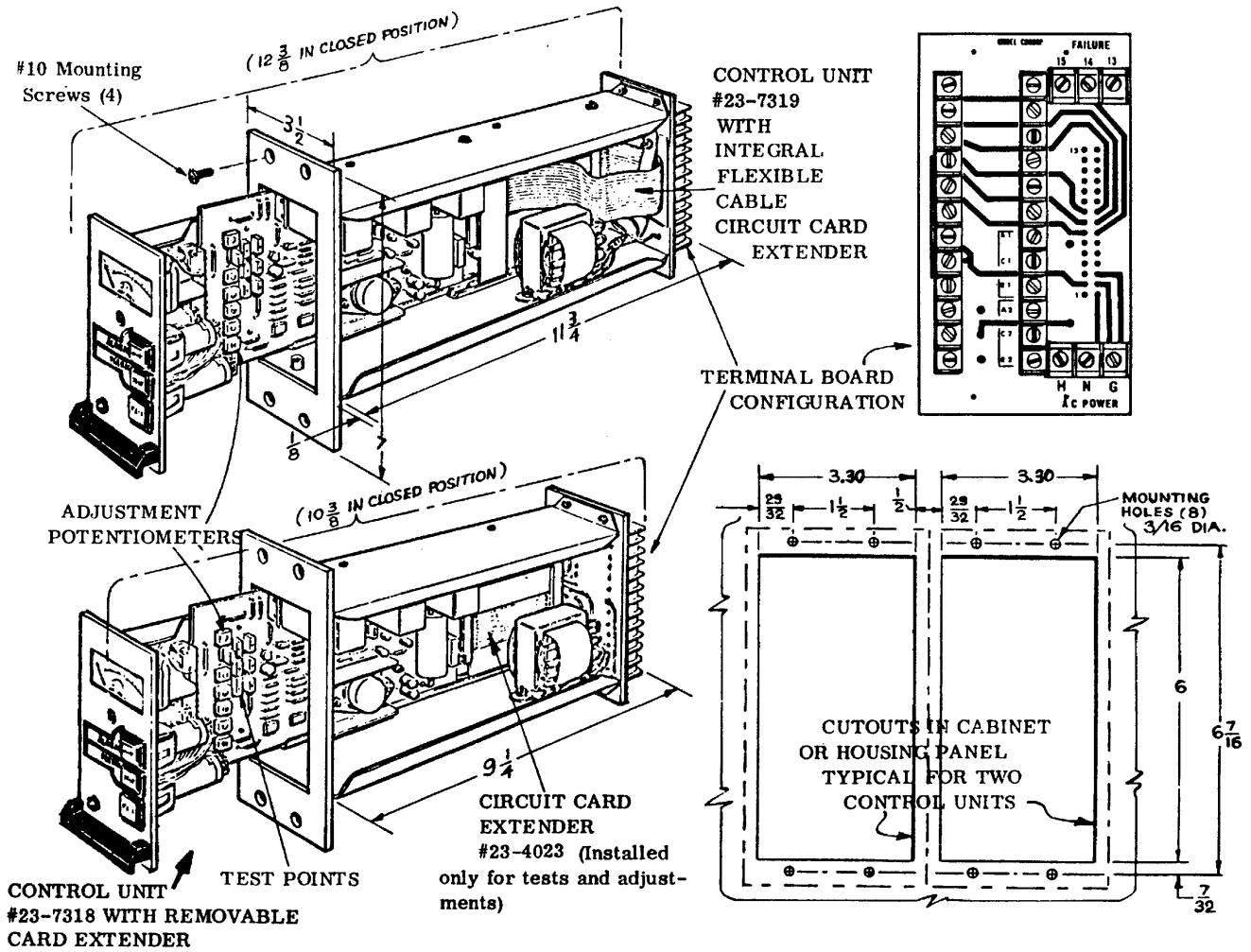

Figure 2-3. CD800P Control Unit Installation Data

23-9617
8/23/77

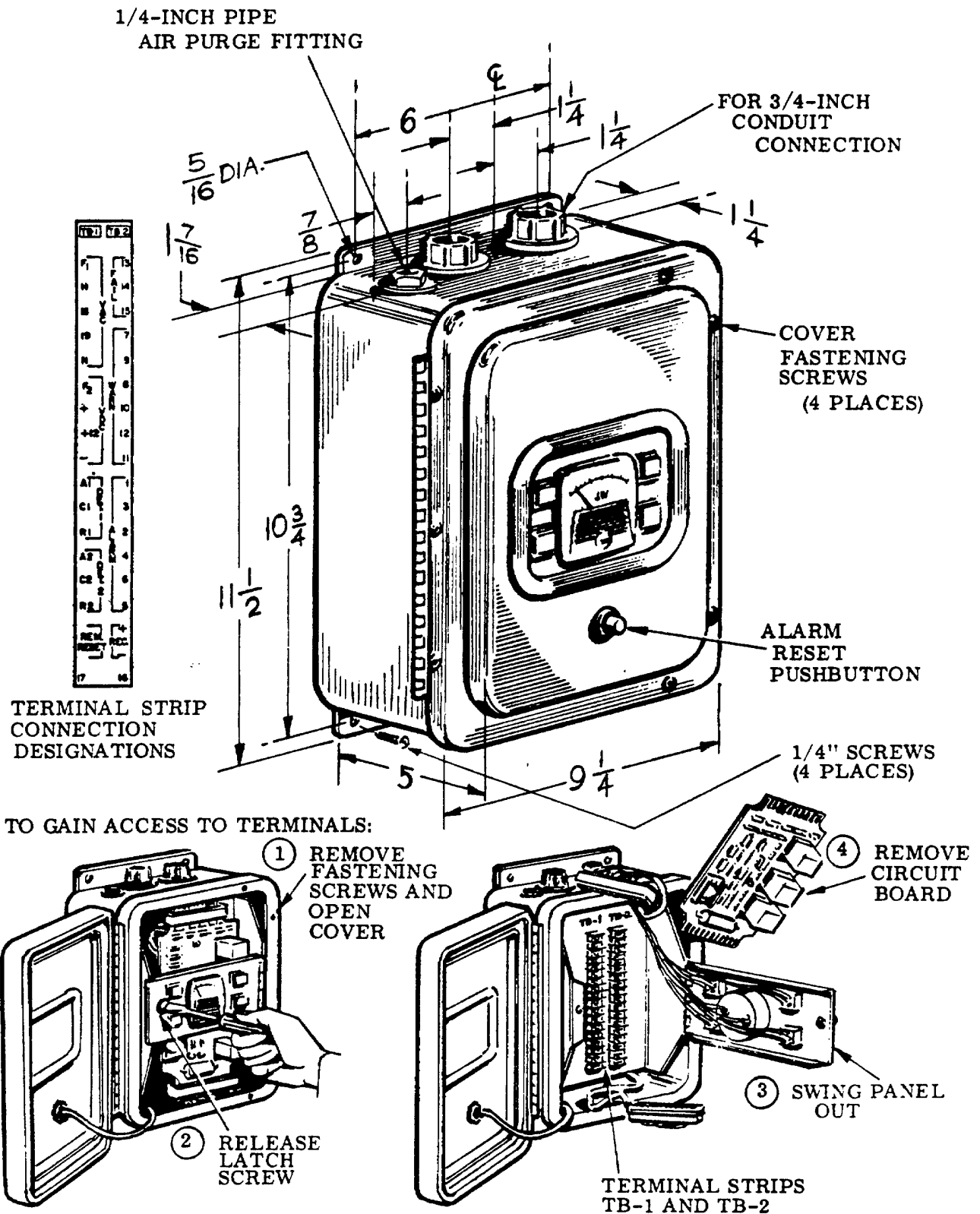

Figure 2-4. CD800W and 802W Wall-mounting Cabinet Installation

23-9617
7/1/76

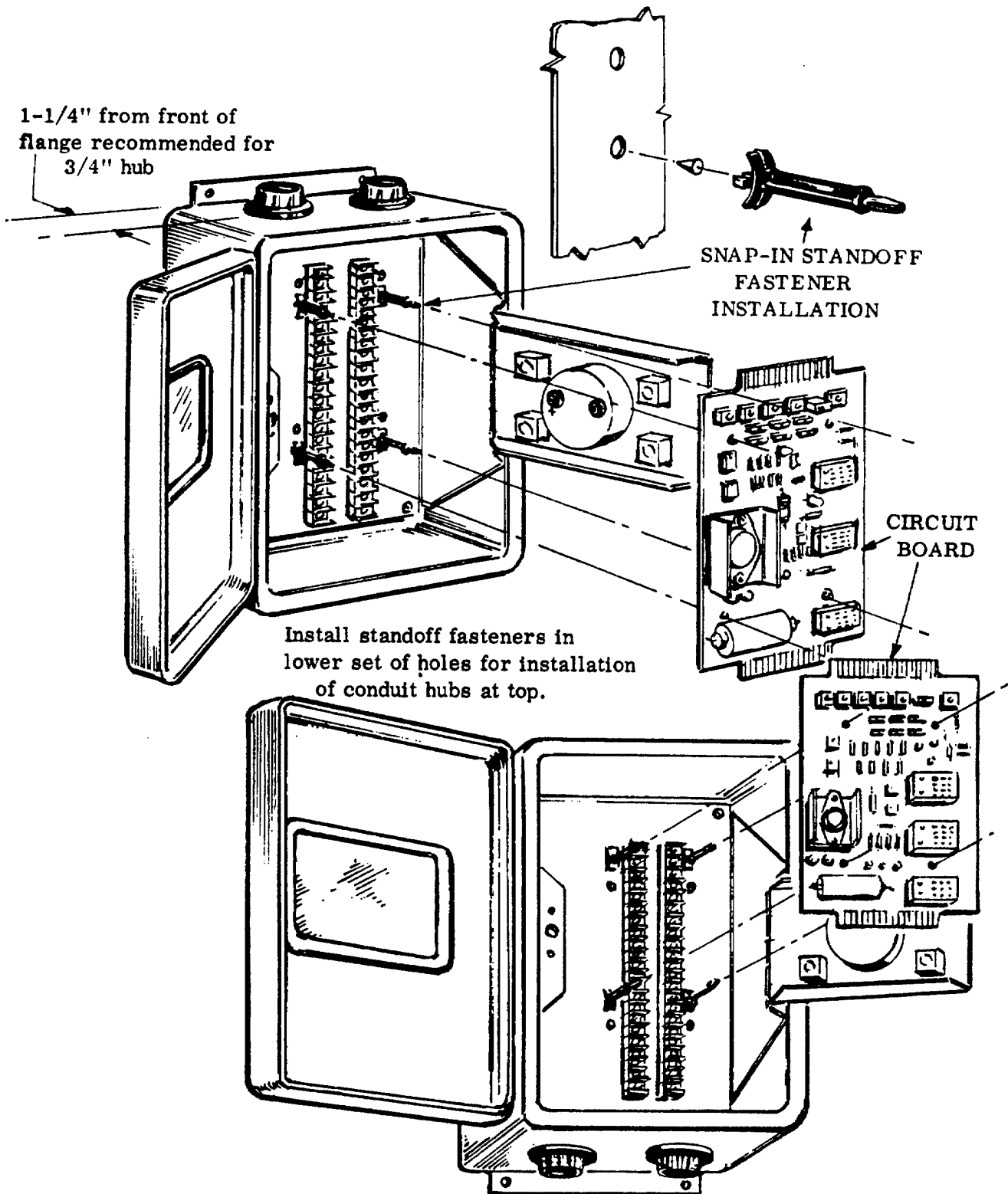

Figure 2-5. Installation of Circuit Board Standoffs for CD800W and CD802W Cabinets Without Factory-installed Conduit Hubs

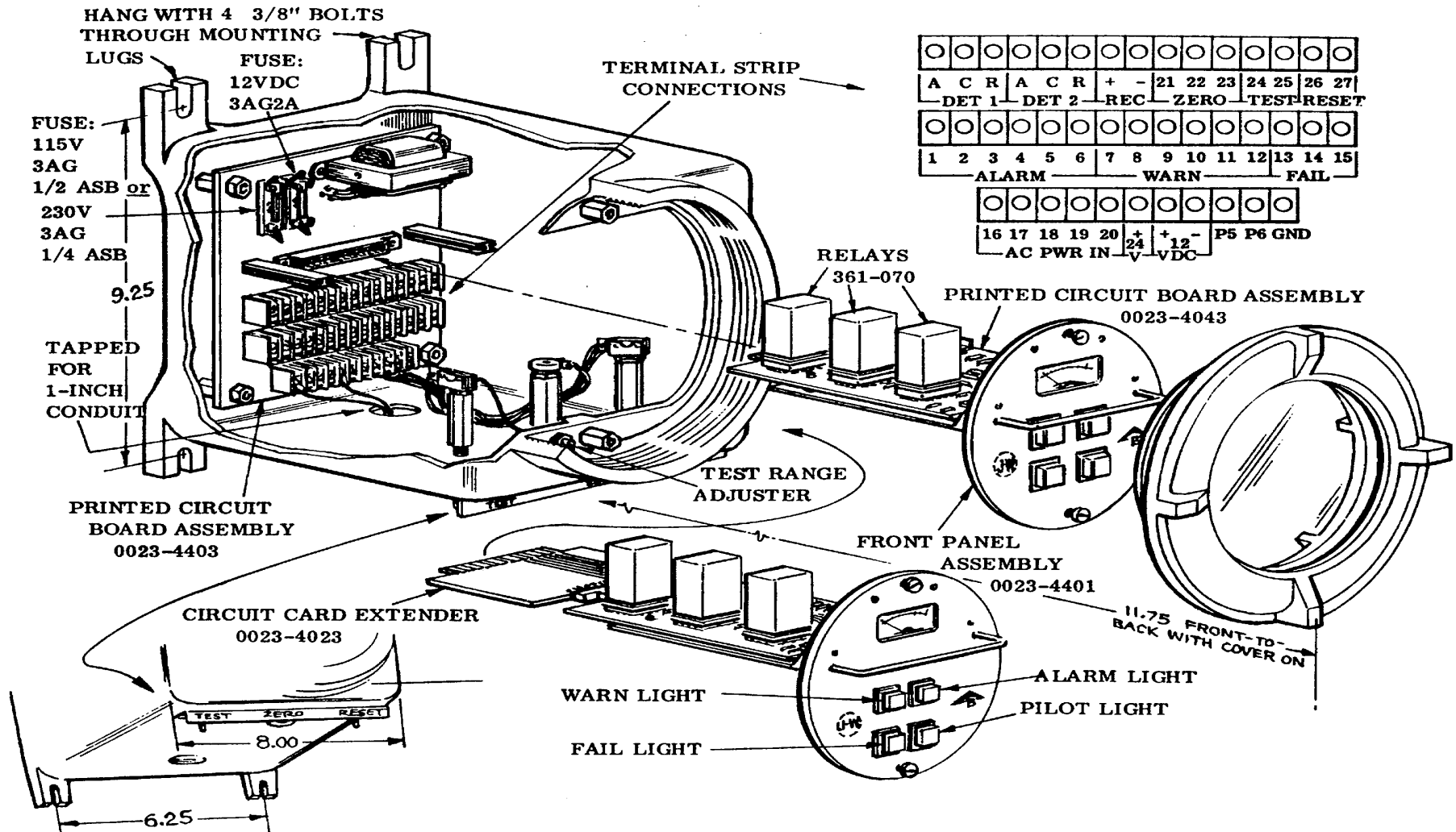
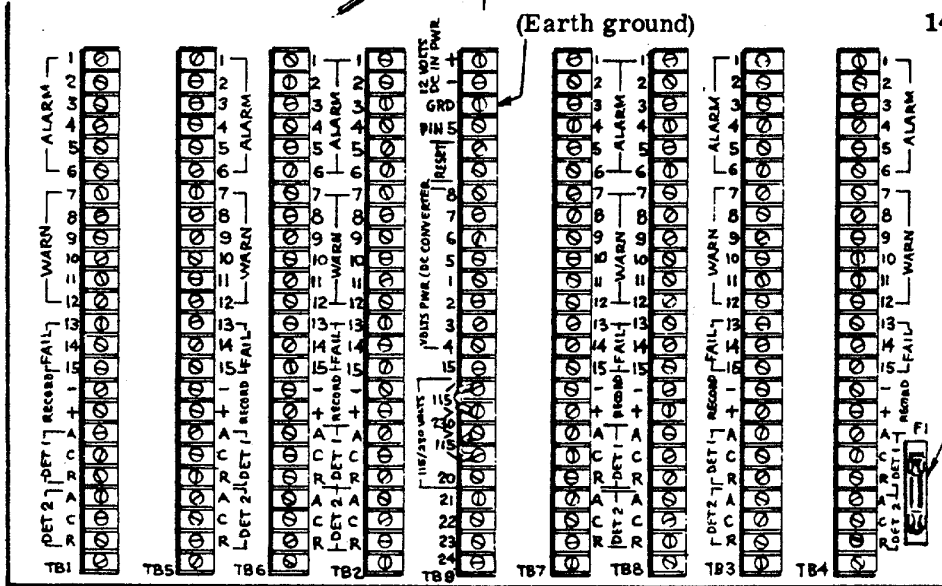
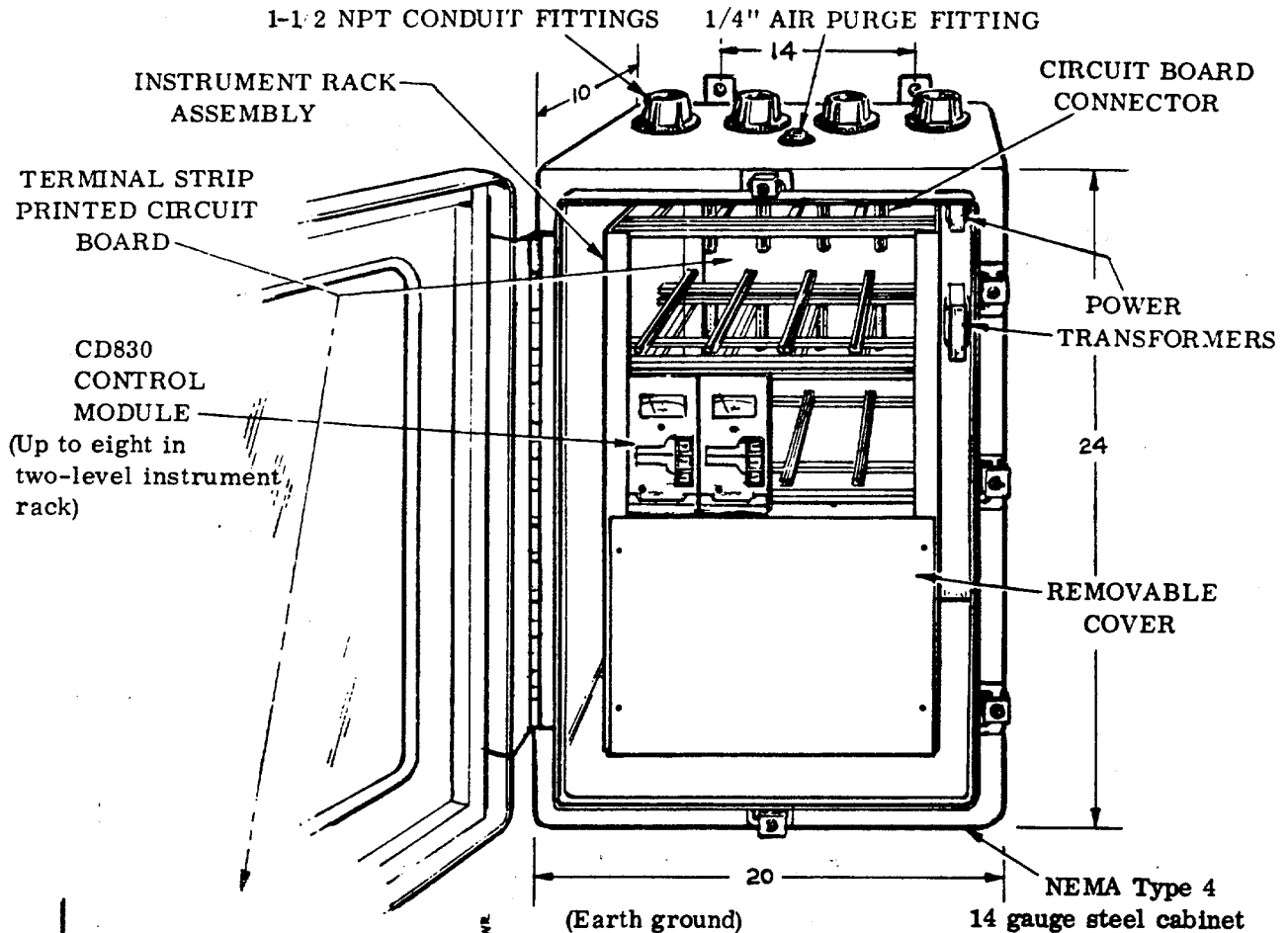

Figure 2-6. CD800X and CD802X Control Unit



FUSE F1
 (W8: 3AG-2ASB,
 #355-741;
 W4: 3AG-1A,
 #355-711)

FUSE F2,
 located top
 center on
 terminal board:
 3AG8A,
 #355-722

TERMINAL STRIPS for detector, power, alarms, recorder, and reset connections (accessible at inside rear with cabinet door open and front cover panel removed)

23-9617
 5/9/80

Figure 2-7. CD830W8 Wall-mounting Cabinet for up to Eight Control Modules (23-7176), or CD830W4 (23-7175) for up to Four Control Modules (with top rack covered)

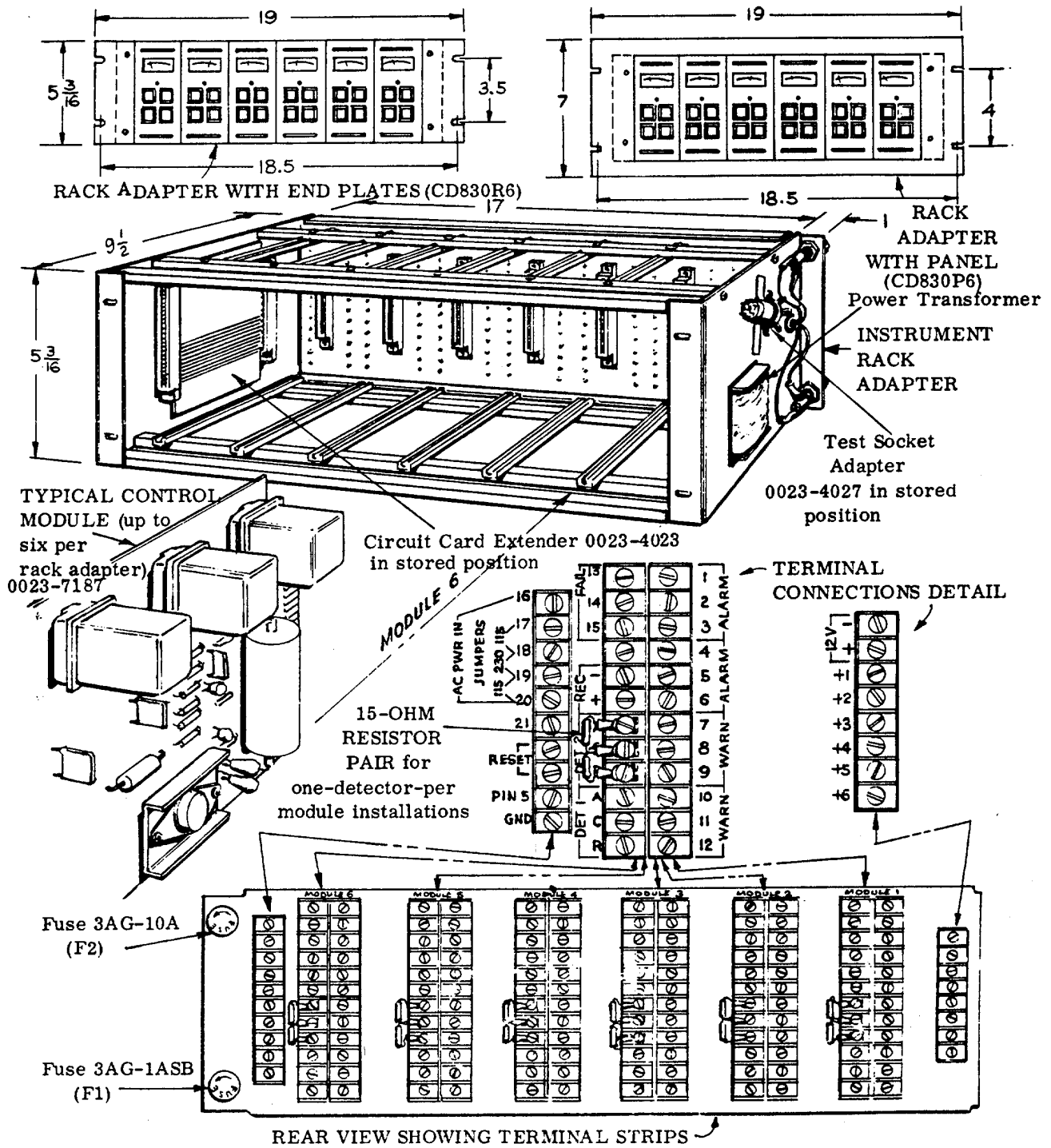
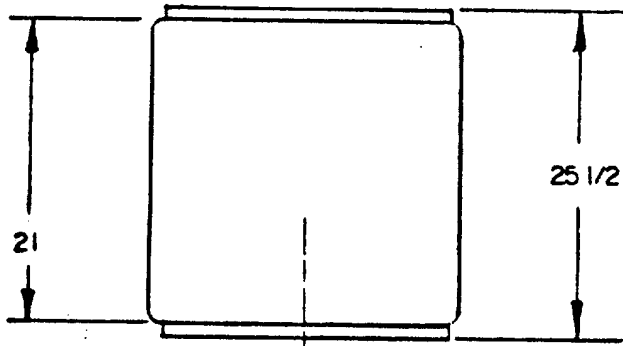

Figure 2-8. CD830 and CD832 Standard Instrument Rack Adapter for Up to Six Control Modules

23-9617
7/1/76



NOTE: CABINET IS EMCOR NO. FR-126 A

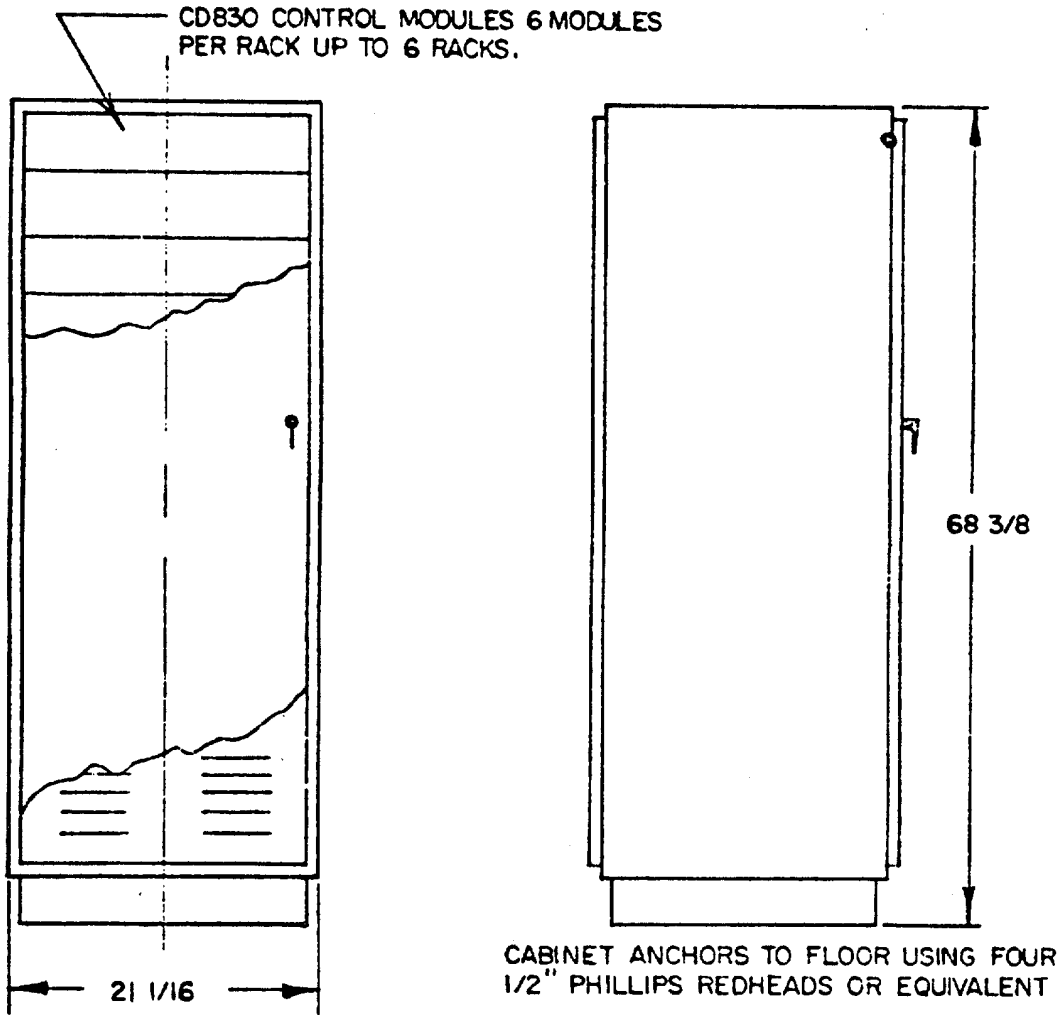

Figure 2-9. CD830F Floor-standing Instrument Cabinet

23-9617
7/1/76

2-5 POWER SUPPLY CONNECTIONS.

CD800/830 and CD832 Series Control Modules may utilize the following external power sources:

1. 120/240 VAC external power service line.
2. Isolated 120/240 VAC plant power unit.
3. 12 VDC secondary (standby) power supply.
4. Static power converter to accommodate 16 to 35 VDC secondary power supply (compatible with 24 V, 32 V battery).
5. 12V lead-acid battery and charger.

2-5.1 POWER CONNECTIONS. External power connections to power terminals for CD800/830 series models are designated in Table 2-1 and Figures 2-11 through 2-15.

Power transformers are factory-wired for 120 VAC operation, as shown in Figure 2-10 diagram A. Transformer wires may be reconnected for 240 VAC operation, if required, as shown in diagram B.

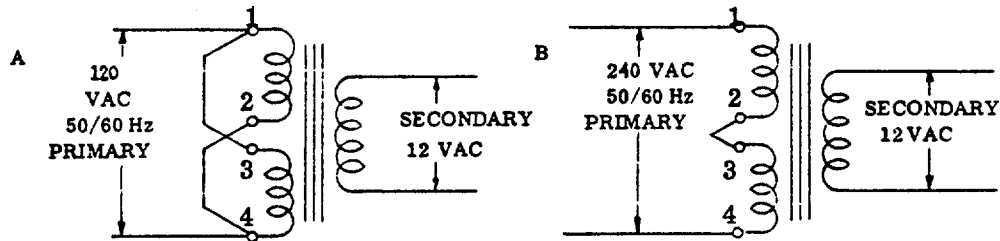

NOTE: Model CD800X third wire ground (green) is connected to terminal board terminal labeled "GND." Model CD800P third wire ground (green) is connected to AC power terminal strip, terminal "G."

Figure 2-10. Transformer Wiring for 120VAC and 240VAC External Power

2-5.2 DC SECONDARY (STANDBY) POWER SUPPLY. Both AC and DC power may be connected simultaneously, so that DC power will be automatically supplied should the main AC power input be interrupted. The standby power supply should not operate from the same generator, converter, or other device that provides the primary power supply. DC + and - power connections to the control module or module assembly terminal board are marked 12 V, and + and -, or VDC, +12 and -, depending on the particular model to be installed (CD800P/CD802P: terminals TB-2, 6(+) and 7(-)).

2-5.3 STATIC POWER CONVERTER. If 24-or-32-volt batteries (or other 16-to-35-

23-9617
7/3/79

INCOMING POWER LEADS	TERMINAL CONNECTIONS				
	CD800X/802X	CD800P/802P	CD800W/802W	CD830/832 W4/W8	CD830/832 R6
120/240 VAC Black (Hot) Wire	16	H	F1 if fused. H if not fused.	20	16
120/240 VAC White (Neutral) Wire	20	N	N	16	20
120/240 VAC Green (Ground) Wire	GND	GND	To "GROUND" terminal on chassis	To "GROUND" terminal on chassis	To Chassis
120 VAC Jumper Wires	17 to 18 and 19 to 20	Factory- connected	H to 18 and 19 to N	16 to 17 and 18 to 19	17 to 18 and 19 to 20
240 VAC Jumper Wires	18 to 19	Change jumper wires at trans- former(Fig. 2-13)	18 to 19	17 to 18	18 to 19

Table 2-1. AC Power Terminal Connections, CD800/830 Series Models

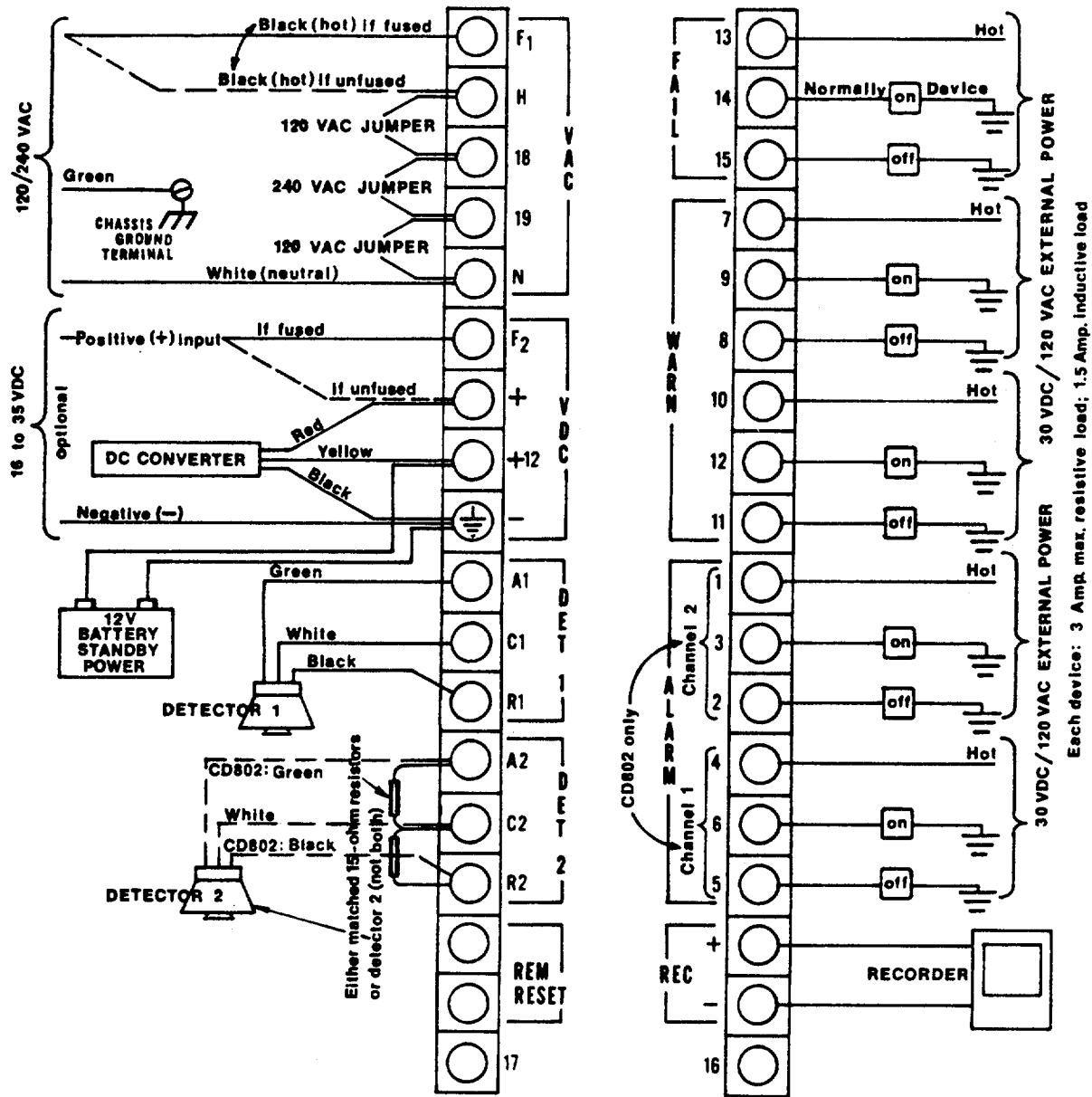

CAUTION: Do not connect ground or other wires to unused terminal screws. Such connections may short-circuit and destroy circuit board traces to which the terminal posts are connected.

Figure 2-11. CD800W and CD802W External Wiring Connections Diagram

23-9617
10/3/78

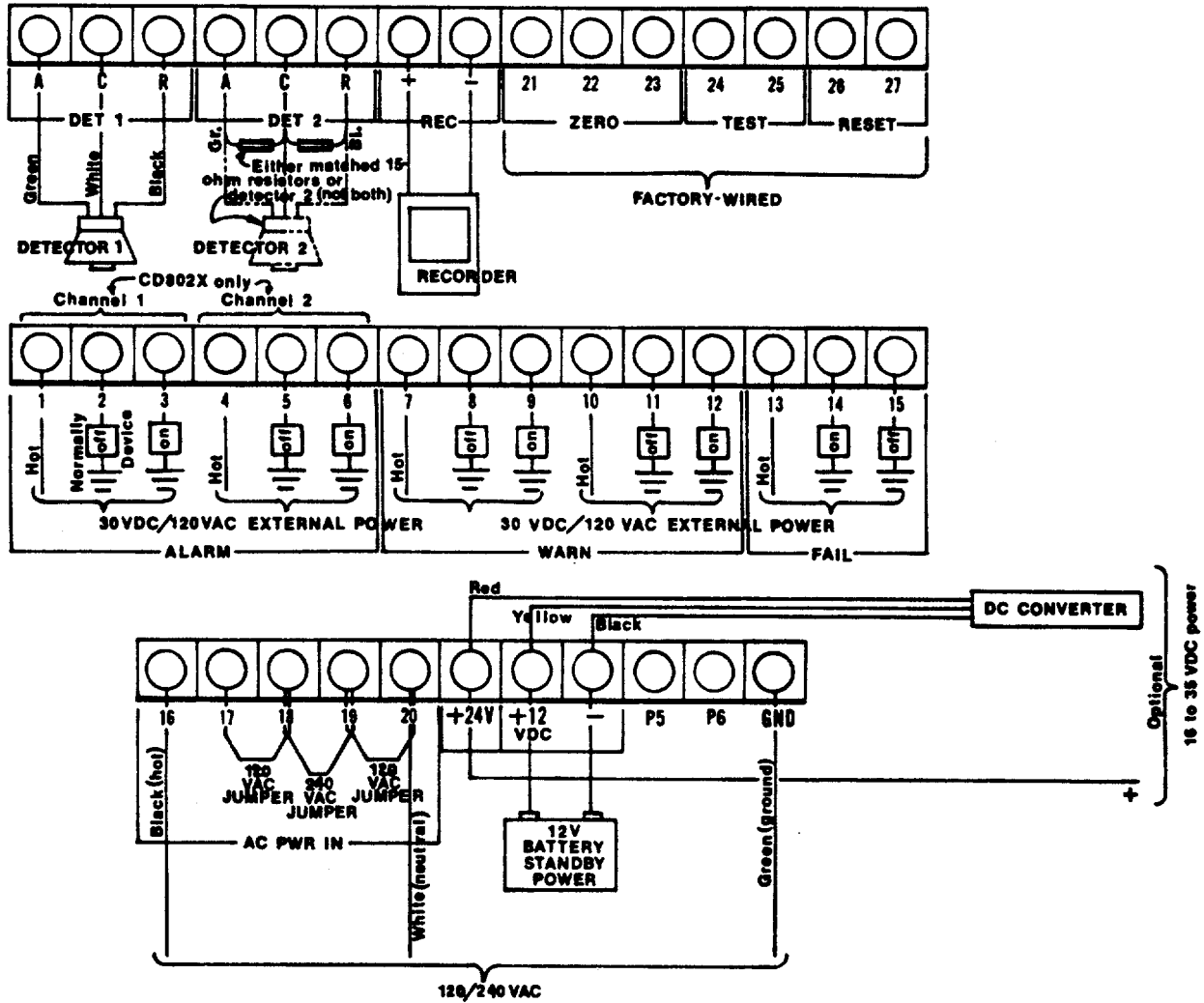

CAUTION: Do not connect ground or other wires to unused terminal screws. Such connections may short-circuit and destroy circuit board traces to which the terminal posts are connected.

Figure 2-12. CD800X and CD802X External Wiring Connections Diagram

23-9617
7/17/78

CAUTION: Do not connect ground or other wires to unused terminal screws. Such connections may short-circuit and destroy circuit board traces to which terminal posts are connected.

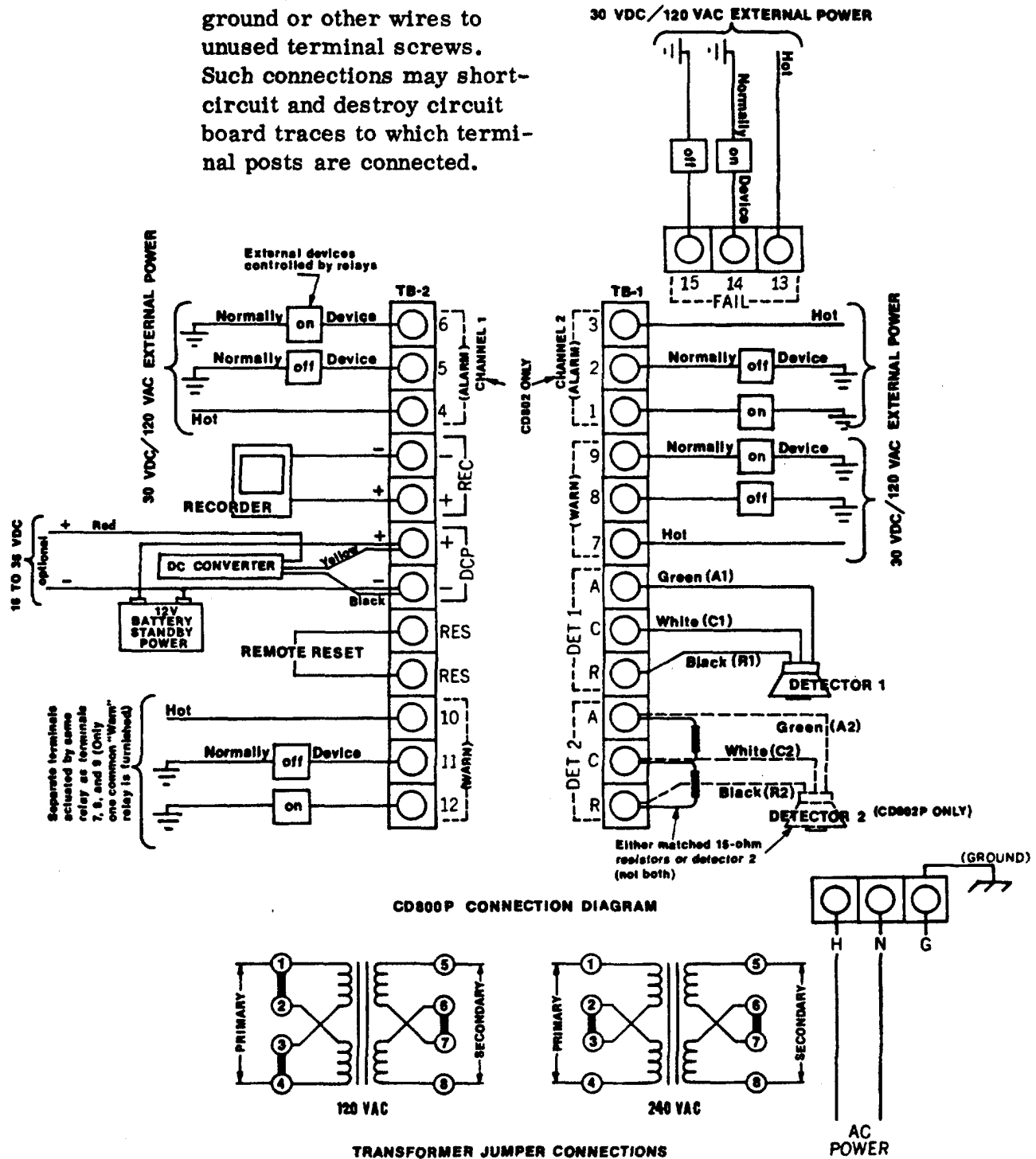

Figure 2-13. CD800P and CD802P External Wiring Connections Diagram (CD800P or PF Enclosure)

23-9617
2/23/78

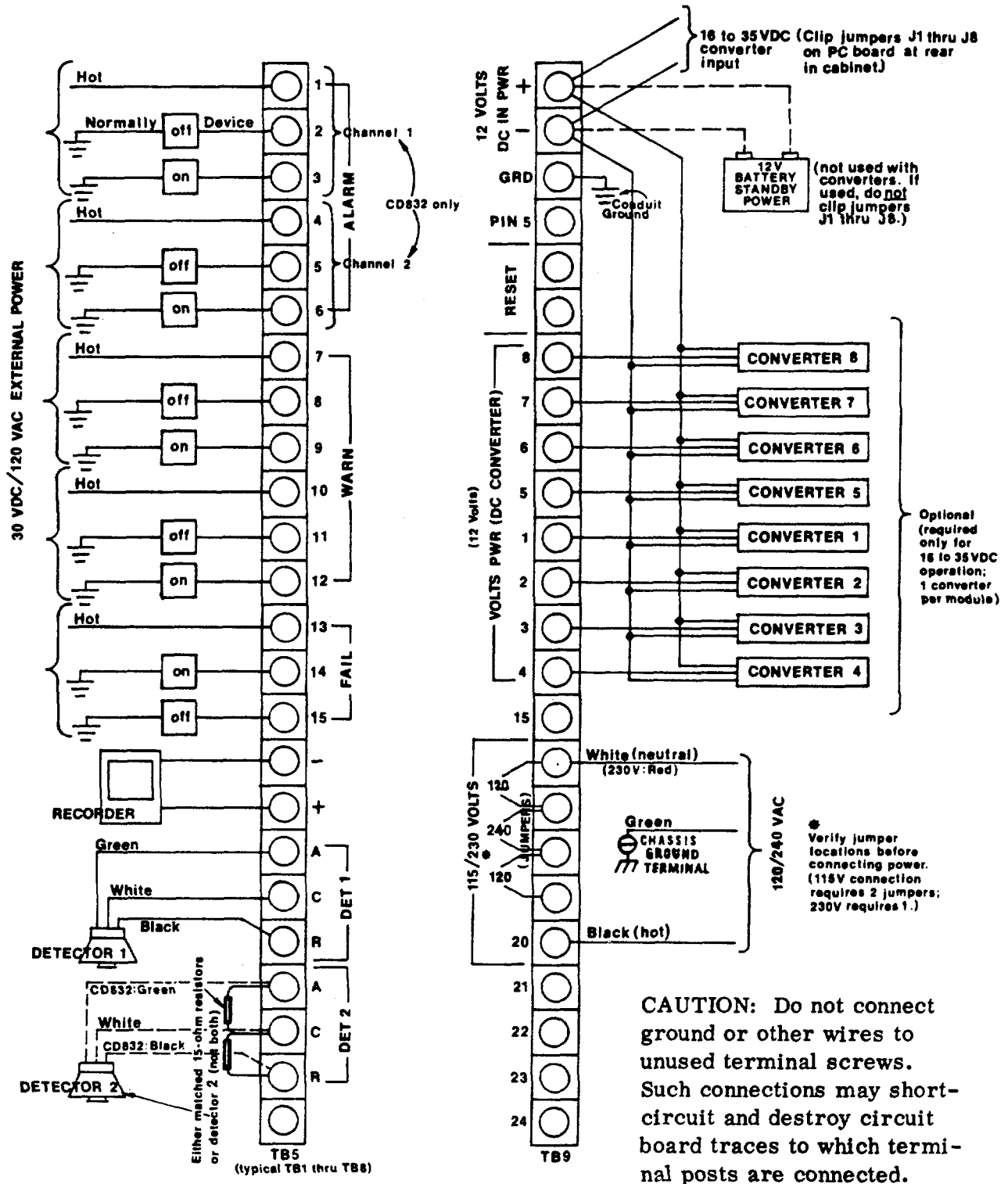

Figure 2-14. CD830W4/CD830W8 and CD832W4/CD832W8 External Wiring Connections Diagram

23-9617
10/3/78

CAUTION: Do not connect ground or other wires to unused terminal screws. Such connections may short-circuit and destroy circuit board traces to which the terminal posts are connected.

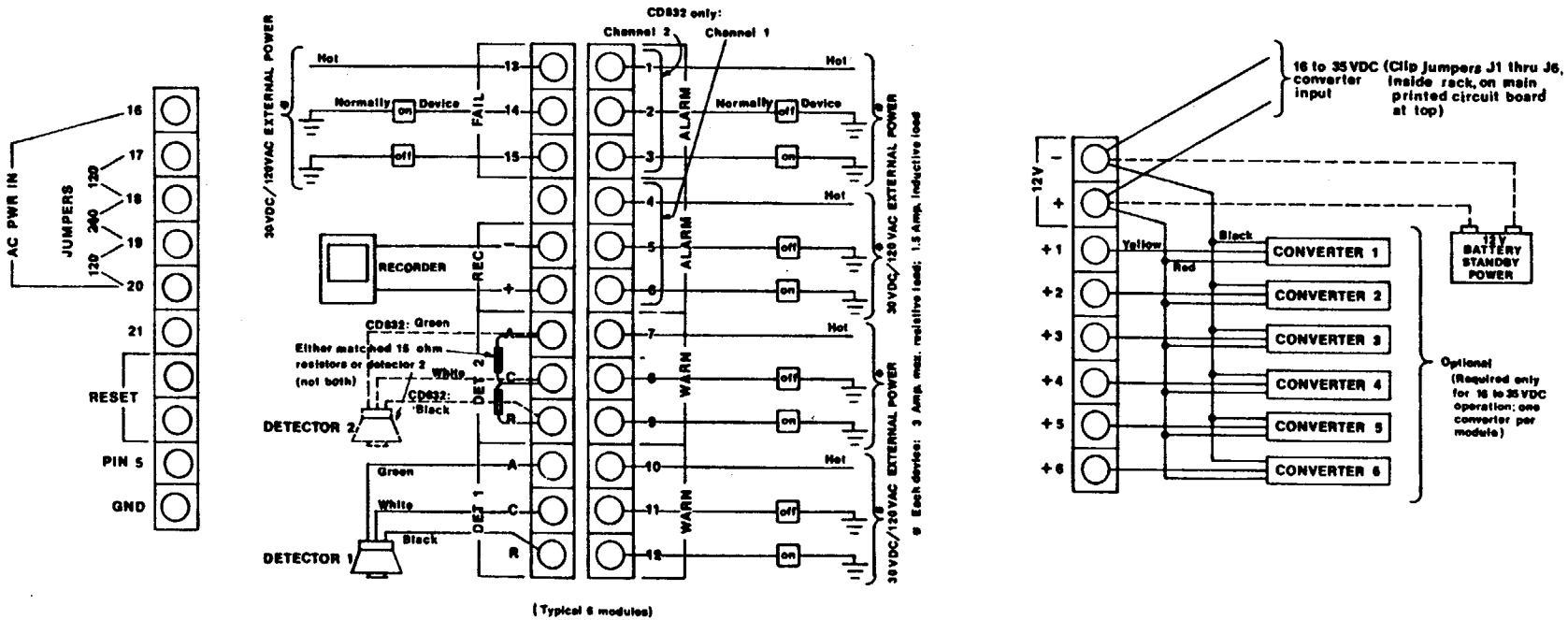

Figure 2-15. CD830R6 and 832R6 External Wiring Connections Diagram

2-5 POWER SUPPLY CONNECTIONS (continued)

2-5.3 Static Power Converter (continued)

VDC supply) are to provide a secondary power supply, a static power converter available on order can be installed to provide the 12 VDC required by the control unit(s). Connect the converter to the control unit terminal board as follows:

To connect converter to CD800W/CD802W control unit:

1. Connect converter red wire (+16-35 VDC) to terminal board VDC+.
2. Connect converter yellow wire (+12 VDC) to terminal board VDC +12.
3. Connect converter black wire (common-) to terminal board VDC-.
4. Connect external power (16 to 35 VDC) positive input lead to terminal board VDC + if control unit is unfused, or to VDC F2 if control unit is fused.
5. Connect power negative lead to terminal board VDC-.

To connect converter to CD830R6/832R6 control module rack terminals:

1. Clip jumpers J1 through J6 (located inside rack on main printed-circuit board at top) to eliminate common DC input circuit.
2. Connect one DC converter for each control module as shown in Figure 2-16.

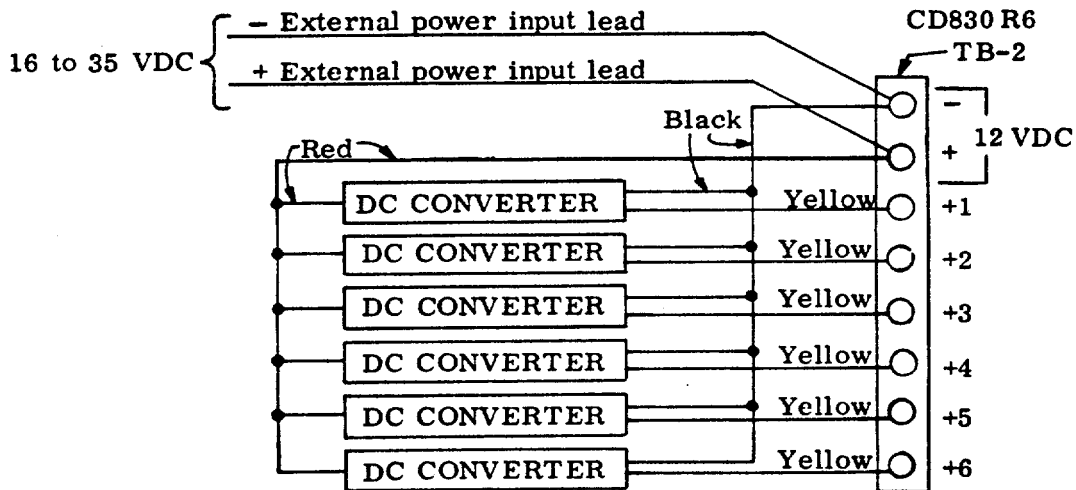

Figure 2-16. DC Converter Terminal Connection Diagram - CD830R6

NOTE: To connect converter to CD800X or to CD800P, refer to Figure 2-12 or 2-13.

23-9617
7/1/76

2-5 POWER SUPPLY CONNECTIONS (continued)

2-5.4 12-VOLT LEAD-ACID BATTERY AND CHARGER. A 12-Volt lead acid battery can be “floated” on a trickle-charger connected to the AC power supply to provide uninterrupted service for four hours (dependent on system load current), in the event of AC power failure. No transfer circuitry or switchover relays are required; connections from battery to DC + and-power input terminals of the control module assembly terminal board complete the installation.

2-6 DETECTOR INSTALLATION

Installation of CD800/830 and CD802/832 Series detectors includes the following steps:

1. Installing conduit or cables.
2. Installing wires in conduit (3 conductors per detector assembly).
3. Testing for open-circuit, or leakage conditions in conduit wires.
4. Connecting conduit wires to detector.
5. Installing detector assembly.
6. Connecting conduit wires from detector to control unit assembly terminals.
7. Testing operating voltages and compensating for conduit wire voltage drops.
8. Calibrating detector and control module circuitry with a standard mixture of gas and air.
9. (If required) installation of sample lines, filter traps, etc., for sample-drawing-type-detectors.

2-6.1 INSTALLING CONDUITS: Install conduits between control module assembly and detector to contain cable with power and detector circuit wires. The conduit fitting to which the detector is coupled must be compatible with the detector end fitting as follows:

Explosion-proof and weatherproof, diffusion-sampling
 Detector #0023-4012: ¾ -14 NPT male thread

Duct-mounting, diffusion-sampling
 Detector #0023-4014: ¾ -14 NPT female thread

Sample-drawing
 Detector #0023-4017 ¾ -14 NPT male thread

23-9617
 7/1/76

2-6 DETECTOR INSTALLATION (continued)

2-6.1 Installing Conduits (continued)

Explosion-proof, weatherproof, diffusion-sampling
 Detector #800-086 ½-14 NPT female thread

Explosion-proof, weatherproof, diffusion sampling, corrosion-proof
 Detector #0023-7317 ½-14 NPT female thread

The #0023-4014 detector assembly is designed to mount directly in the duct to expose the detector element to the gases being sampled. Mount #0023-4014 detector in the following manner.

1. Locate a 1-¼" diameter hole in the duct wall so that detector body can be inserted through the plate assembly and project into the duct.
2. Secure the plate assembly to the duct wall using four sheet metal screws through holes provided.
3. Insert detector body into the plate assembly and secure by tightening the two knurled thumb screws.
4. ¾" flexible conduit may be used to allow a convenient means of removing the detector assembly for servicing.

NOTE: For potentially explosive areas, install wiring in accordance with National Electrical Code Articles 501-517, which specify explosion-proof fitting, conduit sealing, and special wiring techniques.

2-6.2 INSTALLING DETECTOR WIRING. Use good-quality wire or cable containing three conductors in one jacket. Install with a minimum number of splices. Cable laid in open trays near AC high-power lines, or circuits to equipment which may generate radio-frequency (RF) signals, commutation noise, or ignition noise, should be sheathed or shielded. The outer braid of shielded cable must not contact conduit or junction boxes, and must be grounded only at the control module end. The cable should contain green, black, and white wires.

Maximum resistance allowable in black and green (A and R conduit wires is 2.5 ohms per wire (5 ohms total A and R loop resistance, with A and R wire resistances the same within 0.1 ohm). A 1. 25-ohm maximum resistance is allowable where two detectors share a common power lead from terminals A and R to a remote point where power leads split.

Wire gauge may be determined with respect to length of wire run as follows:

23-9617
 7/1/76

2-6 DETECTOR INSTALLATIONS (continued)

2-6.2 Installing Detector Wiring (continued)

1. When both wire runs are within 20 percent of equal distance, consult Table 2-2 for appropriate wire gauge, and install same-size wire for both runs. Use of #16 AWG wire is desirable even for very short runs, and may be used to simplify wire selection where cost of wire is not greatly significant.
2. If the two wire runs are of unequal lengths: First choose wire size from Table 2-2 for the longer run (if marginal, choose next size larger), then determine exact wire resistance from "OHM-PER-FOOT" column of Table 2-2. Next, for the second detector, choose a smaller wire gauge from Figure 2-17 to obtain as nearly as possible the same resistance as the wire for a longer run. (Both sensors must operate at nearly the same voltage; hence voltage drops in the two wire runs must be nearly equal. Voltage drop in wires can be computed by determining resistance in ohms for the length and size of wire, then multiplying by 0.28 amps detector current. Where differences in voltage drops between leads must be reconciled, set detector operating voltage between the values measured at detectors for each in accordance with paragraph 2-6.9, step 7.)
3. Signal return wires to terminals C1 and C2 may be #20 AWG or larger for distances to 1100 feet, or #18 or larger for greater distances.

AWG	Ohms/1000 Ft. at 68°F	Feet/Ohm at 68°F
6	.40	2531
8	.63	1593
10	1.0	1000
12	1.6	630
14	2.5	396
16	4.0	249
18	6.4	157
20	10.2	99

Table 2-2. Resistance of Standard Annealed Copper Wire (Values are approximately, and will vary depending upon resistivity of specific conductor used.) (See also Resistance Graph, Figure 2-17.)

2-6.2.1 Installing Single Detector on CD800/830 or CD802/832 Control Unit. Install a single detector as follows (Figures 2-8 through 2-11):

NOTE: Do not disconnect 15-ohm paired resistors factory-installed on DET 2 terminals A, R, and C.

1. Connect a green wire between detector active element lead (green, banded "A") and control module terminal marked DET 1, A.

23-9617
7/1/76

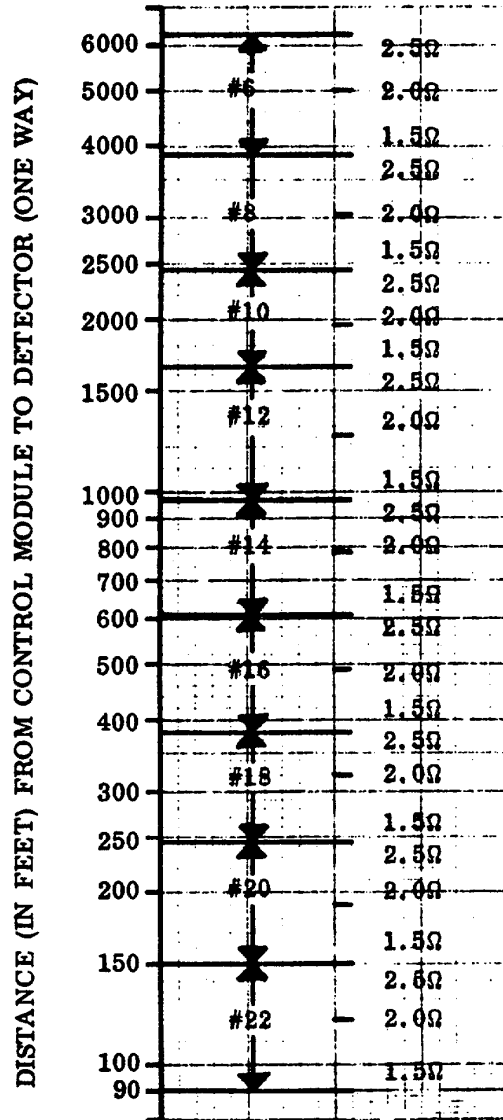
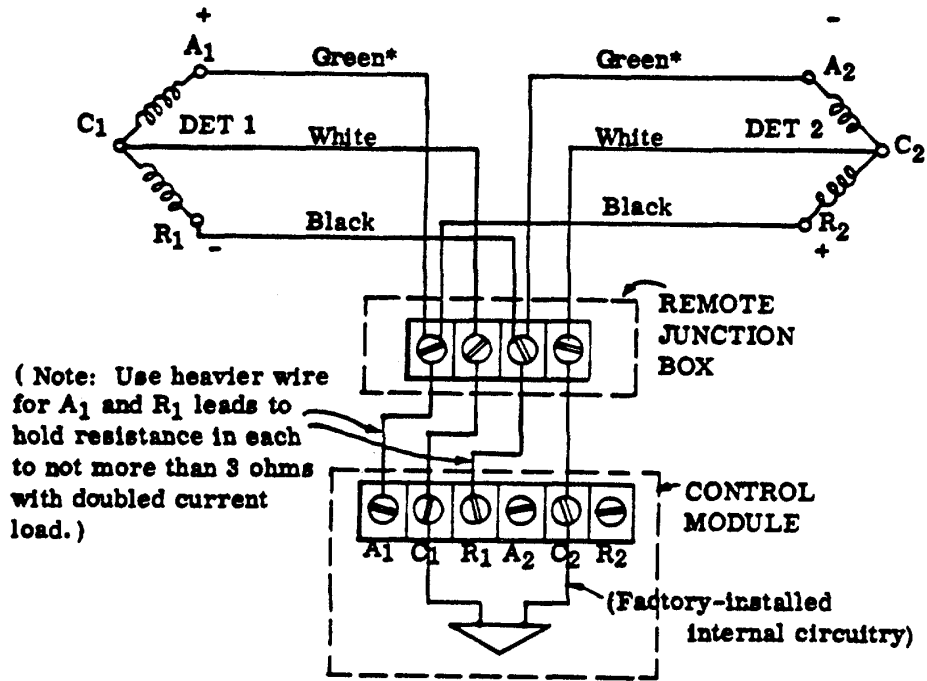
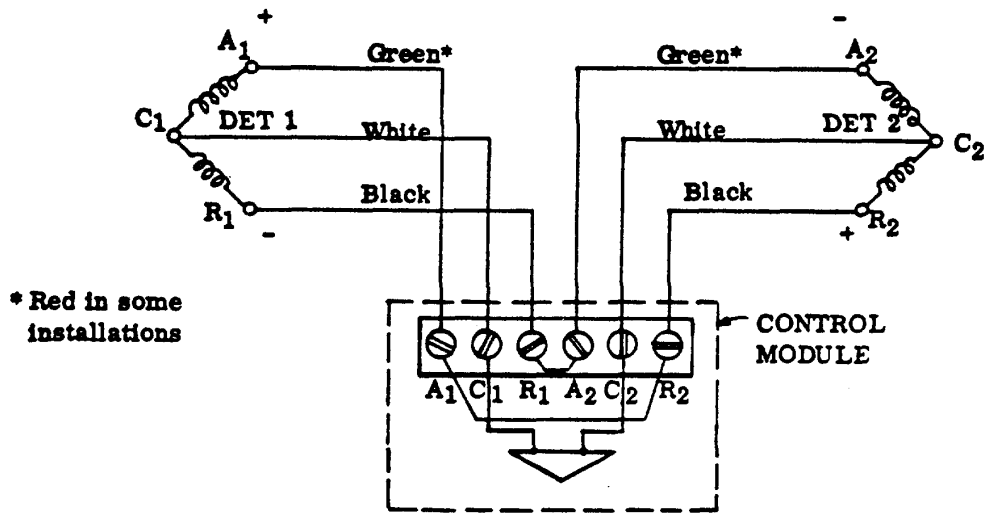

Figure 2-17. Wire Size/Length/Resistance Graph

23-9617
7/1/76



Four Leadwire Connections from Control Module to Junction Box; Six Wires Between Junction Box and Two Detectors



Six Leadwire Connections from Control Module to Two Detectors

Figure 2-18. Alternate Four and Six Leadwire Connections Between Control Module and Detectors of Paired Detector System

23-9617
7/1/76

2-6 DETECTOR INSTALLATION (continued)

2-6.2.1 Installing Single Detector on CD800/830 or CD802/832 Control Unit (continued)

2. Connect a black wire between detector reference element lead (black, banded "R") and control module terminal marked DET 1, R.
3. Connect a white wire between detector single output lead (white, banded "C") and control module terminal marked DET 1, C.

2-6.2.2 Installing Second Detector on One Module, Models CD802/832. Install a single detector as follows (Figures 2-8 through 2-11):

1. Disconnect and remove 15-ohm paired resistor factory-installed on DET 2 terminals A, R, and C.
2. Connect a green wire between detector green lead and control module terminal marked DET 2, A.
3. Connect a black wire between detector black lead and control module terminal marked DET 2, R.
4. Connect a white wire between detector white lead and control module terminal marked DET 2, C.

2-6.3 INSTALLING SECOND DETECTOR FOR CD800/830 SINGLE-CHANNEL MODULES

If two detectors are to be operated from a single CD800/830 control module, wires must be installed to connect the leads of the second detector to an intermediate junction box or to the control module terminals marked DET 2, A, R, and C, as shown in Figure 2-18. (If a single detector only is to be connected to a module, factory-installed, 15-ohm, paired resistors are connected across DET 2 terminals A and C and C and R.) Maximum resistance allowable in A and R conduit wires is 2.5 ohms per wire (or 5 ohms total A and R loop resistance, with A and R wire resistances the same within 1 ohm). A 2.5-ohm maximum resistance is allowable where two detectors to a single module are installed. Wire gauge must therefore be determined with respect to length as follows:

<u>Power supply wires A and R:</u>	0-620 Feet:	#16 AWG
	620-980 Feet:	#14 AWG
	over 980 Feet:	calculate from Table 2-2 or Figure 2-17
<u>Signal return wire C:</u>	0-1100 Feet:	#20 AWG
	over 1100 Feet:	#18 AWG

23-9617
7/26/85

2-6 DETECTOR INSTALLATION (continued)

2-6.4 INSTALLING WIRES FOR ALARM AND CONTROL DEVICES, ALL MODELS. Install, but do not connect wires for alarm and control devices as necessary in conduit.

2-6.5 TESTING FOR OPEN CIRCUITS, SHORT CIRCUITS, AND LEAKAGE IN DETECTOR WIRES. Before connecting conduit wires to detector, to control module, or to alarm or process control equipment, use a high-voltage insulation and leakage tester (such as a "Megger") to test wires for open circuits, short circuits, and for leakage to ground or to another wire. Megger readings for isolated circuits should exceed 100 megohms. Repair defects, if any, to assure proper operation of the detection system, and to prevent damage to components.

NOTE: Warranty is void if abnormally high voltages or currents are applied to detector elements, control modules, or associated equipment.

2-6.6 CONNECTING CONDUIT WIRES TO THE DETECTOR. Using crimp-type connectors, solder lugs, or solder splices (in accordance with National Electrical Code specifications), connect conduit wires to the detector as follows:

1. Connect active element wire A (green or red) of detector head to green conduit wire.
2. Connect reference element wire R (black) of detector head to black conduit wire.
3. Connect signal output wire C (white) of detector head to white conduit wire.

All connections must be clean and tight to assure optimum performance of the monitoring system.

2-6.7 INSTALLING DETECTOR ON CONDUIT. Attach detector to conduit by means of conduit union fitting. In hazardous locations, follow National Electrical Code, Article 501, for sealing conduit wiring in hazardous areas. For outdoor installations, use an explosion-proof drain fitting to allow removal of water that will accumulate in a conduit system, to prevent corrosion or partial shorting at splices.

2-6.8 CONNECTING CONDUIT WIRES FROM DETECTOR TO CONTROL MODULE ASSEMBLY TERMINALS: Install terminal lugs on conduit wires from detector and attach to control terminals with terminal screws as follows (Figures 2-11 through 2-15):

23-9617
7/1/76

2-6 DETECTOR INSTALLATION (continued)**2-6.8 Connecting Conduit Wires from Detector to Control Module Assembly Terminals (continued)**

1. Connect red or green conduit wires to terminal post marked DET 1, A on terminal panel (Model CD800P: terminal TB-1, A-1).
2. Connect black conduit wire to terminal post marked DET 1, R on terminal panel (Model CD800P: terminal TB-1, R-1).
3. Connect white conduit wire to terminal post marked DET 1, C on terminal panel (Model CD800P: terminal TB-1, C-1).

If two detectors are to be operated from a single control module, connect red or green, black, and white wires from the second detector conduit to terminal posts DET 2, A, R, and C respectively (Model CD800P: terminals TB-1, A-2, R-2 and C-2). Remove factory-installed resistors from terminals DET 2, A and C, and C and R (CD800P: TB-1, A-2 and C-2, and C-2 and R-2). Figures 2-11 through 2-15 show connections, all models.)

2-6.9 TESTING OPERATING VOLTAGES AND COMPENSATING FOR CONDUIT WIRE VOLTAGE DROPS. Special equipment required:

0-10 V range DC Voltmeter, $\pm 2\%$ accuracy in 5-6 V range.

Test Socket Adapter #0023-4027 (one furnished with each rack assembly)

Circuit Card Extender #0023-4023 (except some CDSOOP models which have built-in extenders, and model CD80OW, for which the card extender is not required. Six-point rack assemblies provide an extender in storage socket at inside left in the chassis. Wall-mounting four and eight-point cabinets have extenders packed inside the cabinet.)

Two people are required to test and adjust operating voltage: one at the control module, and another at the detector. This test must be conducted for each control/detector unit in turn. Test detector operating voltage level and compensating for conduit wire voltage drops in accordance with the following steps:

1. Make certain that power is off at control module (PILOT ON/OFF light unlit on control module panel).

WARNING: Before opening detector housing, use a portable sniffer to determine that no hazardous gas is present in the vicinity.

2. Remove protecting covers from detector sensor element as follows:

23-9617
7/1/76

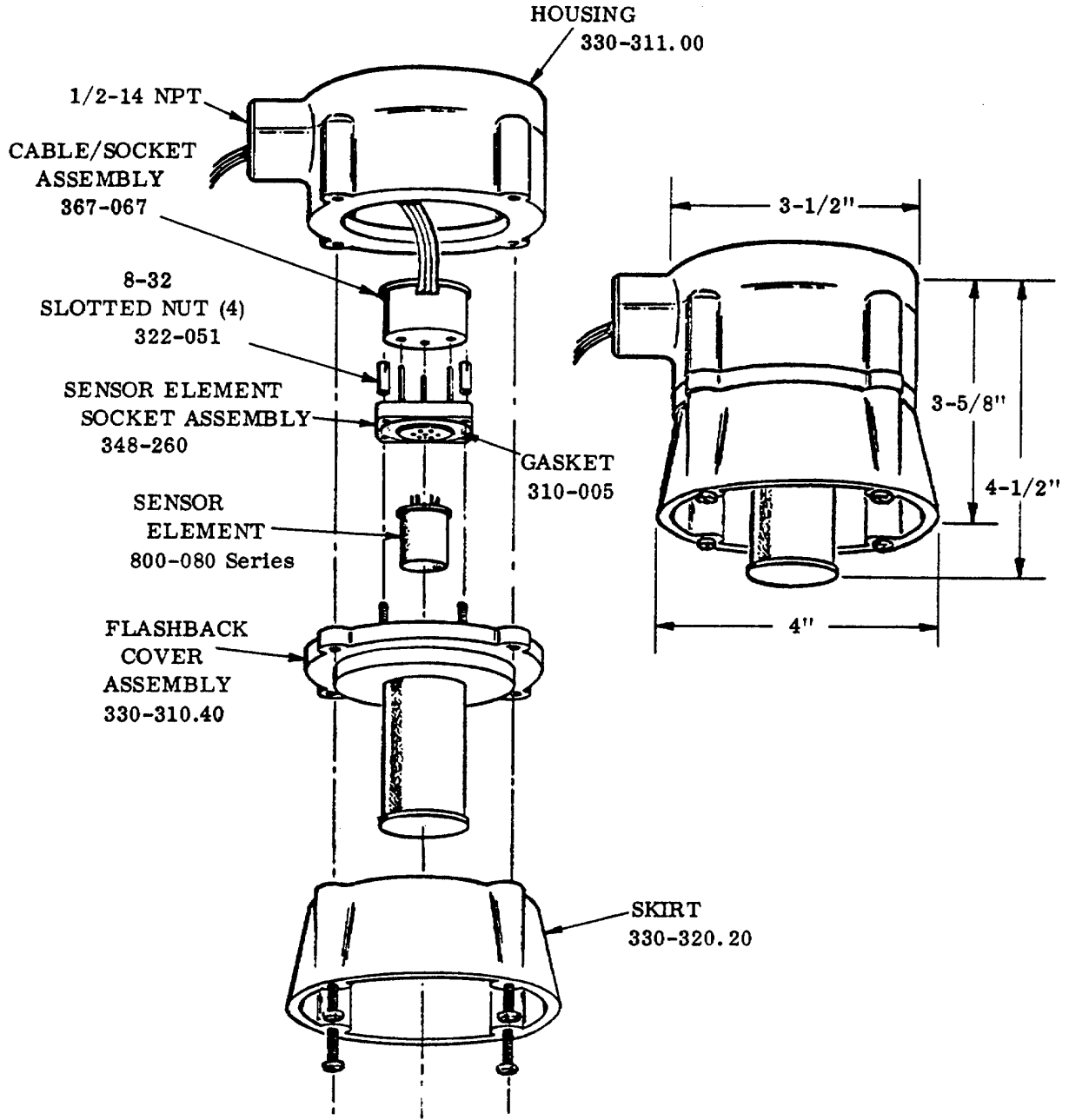
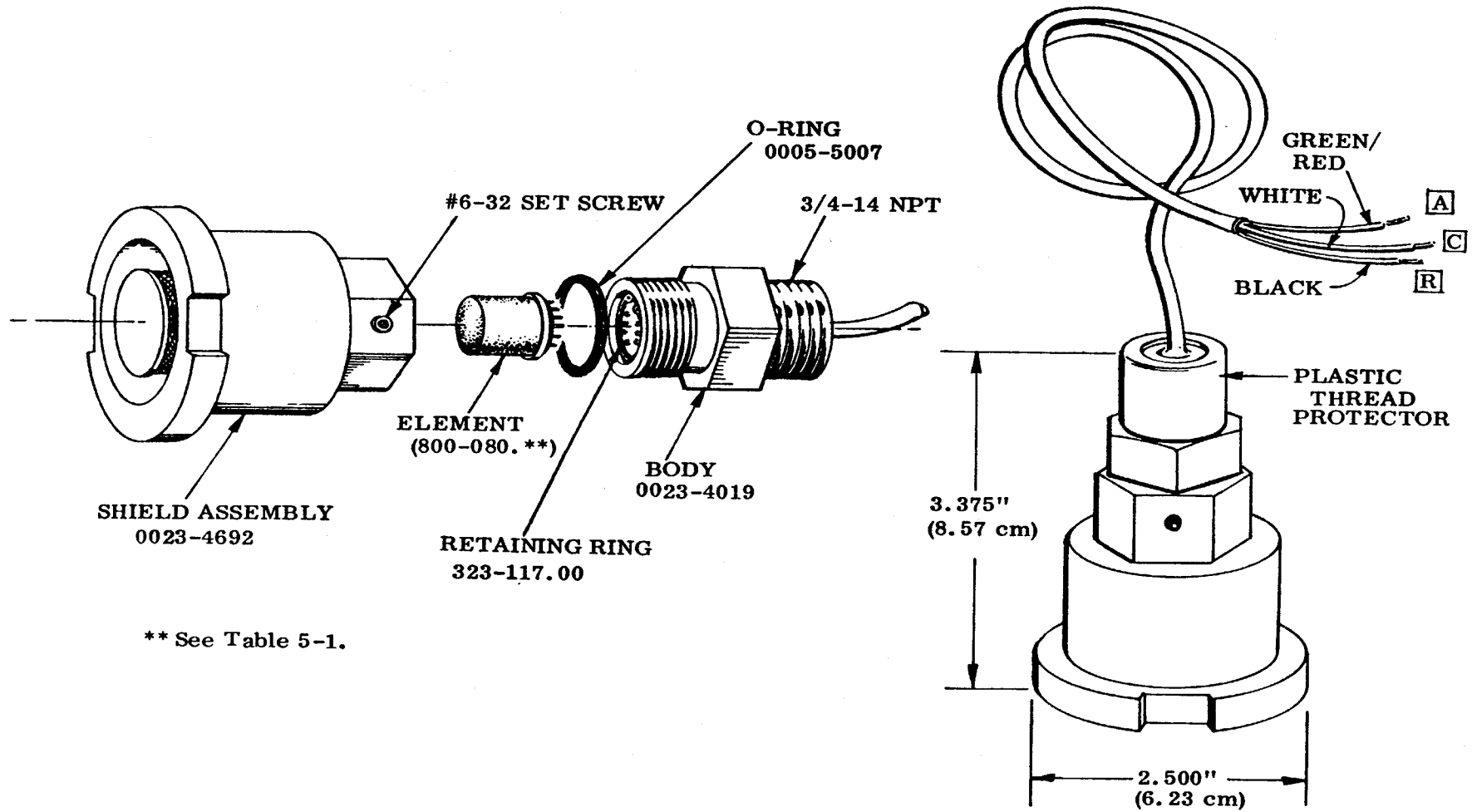

Figure 2-19. Detector Model 800-086 Exploded View

23-9617
7/14/76



** See Table 5-1.

Figure 2-20. Detector Model 0023-4012 Exploded View

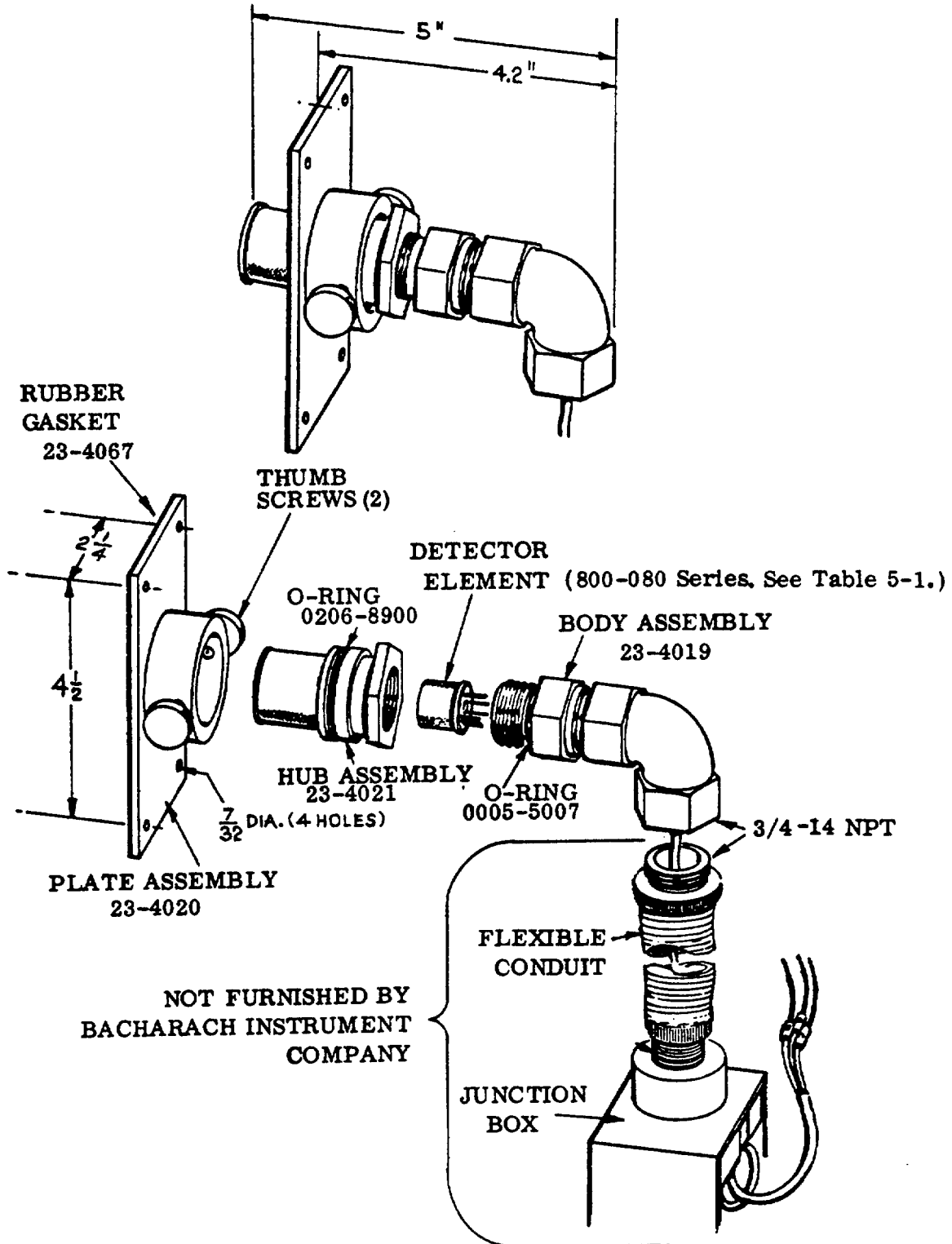

Figure 2-21. Detector Model 0023-4014 Exploded View

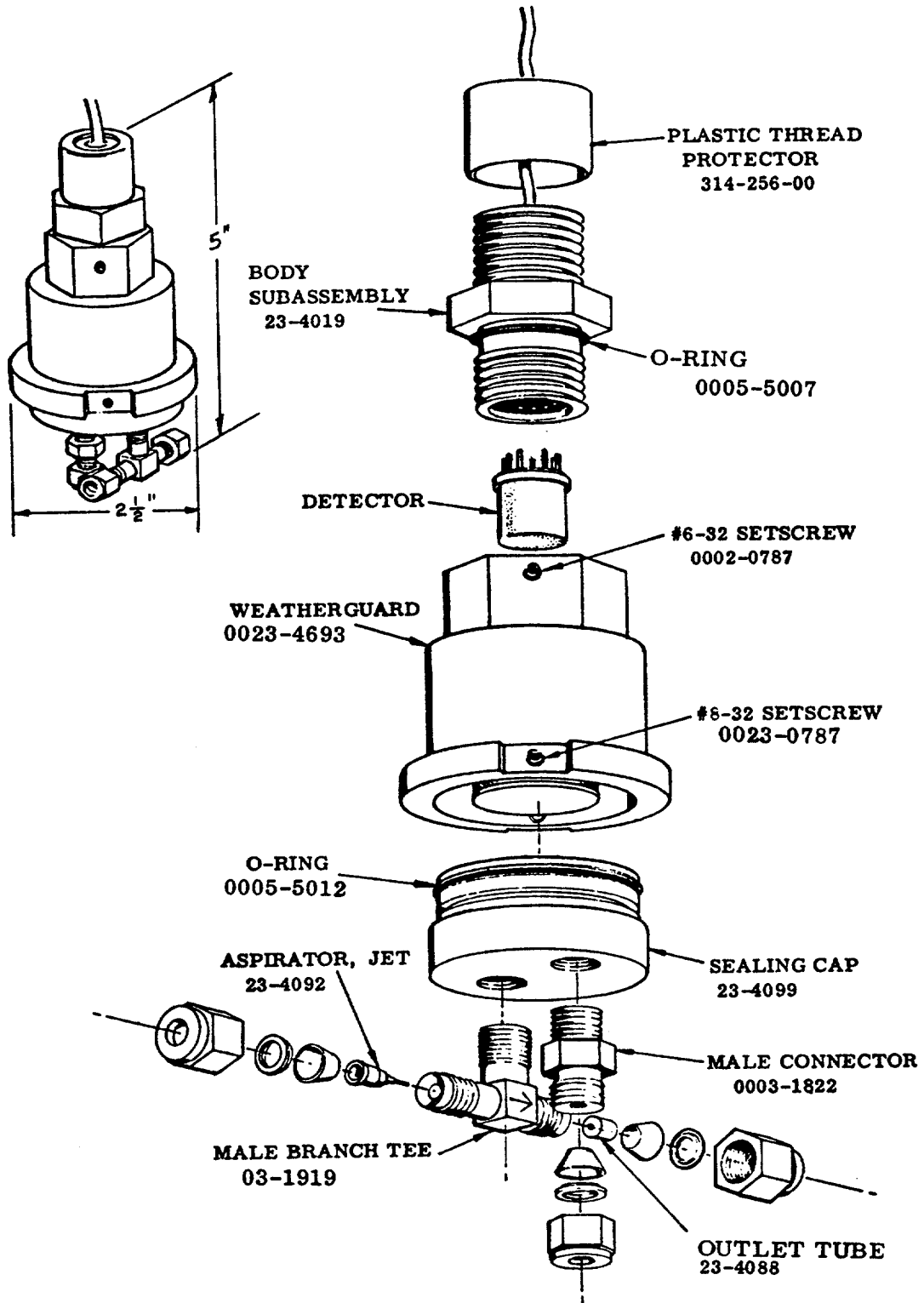

Figure 2-22. Detector Model 0023-4017 Exploded View

23-9617
7/1/76

2-6 DETECTOR INSTALLATION (continued)**2-6.9 Testing Operating Voltages and Compensating For Conduit Wire Voltage Drops . (continued)**

- a) To expose sensor element of detector 800-086 (Figure 2-19): Loosen four screws holding skirt and flashback cover assembly to housing. Remove skirt and withdraw flashback cover from housing. Remove four slotted nuts holding element socket assembly to flashback cover assembly and withdraw flashback cover assembly from socket assembly to expose sensor.

NOTE: Prior to May, 1973, 0005-5007 O-rings were not installed in detectors 0023-4012 and 0023-4017. Order and install the specified O-ring as shown in Figure 2-20 or 2-22 if disassembly reveals that this sealing device is absent.

- b) To expose sensor element of Detector #0023-4012 (Figure 2-20):

Loosen set screw used to secure shield assembly to detector body. Unscrew shield assembly to remove from body and expose sensor element.

- c) To expose sensor element of Detector #0023-4014 (Figure 2-21):

Disconnect detector from conduit coupling fitting. Loosen plate assembly thumbscrew and remove detector from plate assembly. Unscrew and remove hub assembly from body assembly to expose sensor element.

- d) To expose sensor element of Detector #0023-4017 (Figure 2-22):

(1) Break tubing connections at union fittings

(2) Loosen setscrew used to secure aluminum weatherguard housing from body to expose sensor element.

- e) To expose element of Detector #0023-7317 (Figure 2-23):

Remove four hex nuts holding high-humidity shield assembly to housing and remove shield and gasket from flashback cover to housing and remove flashback cover to expose sensor element.

3. Remove sensor element from socket (all detector models) and plug in Test Socket Adapter #0034-4027. Plug sensor element into adapter socket (Figure 2-24). Turn on power.

23-9617
4/15/77

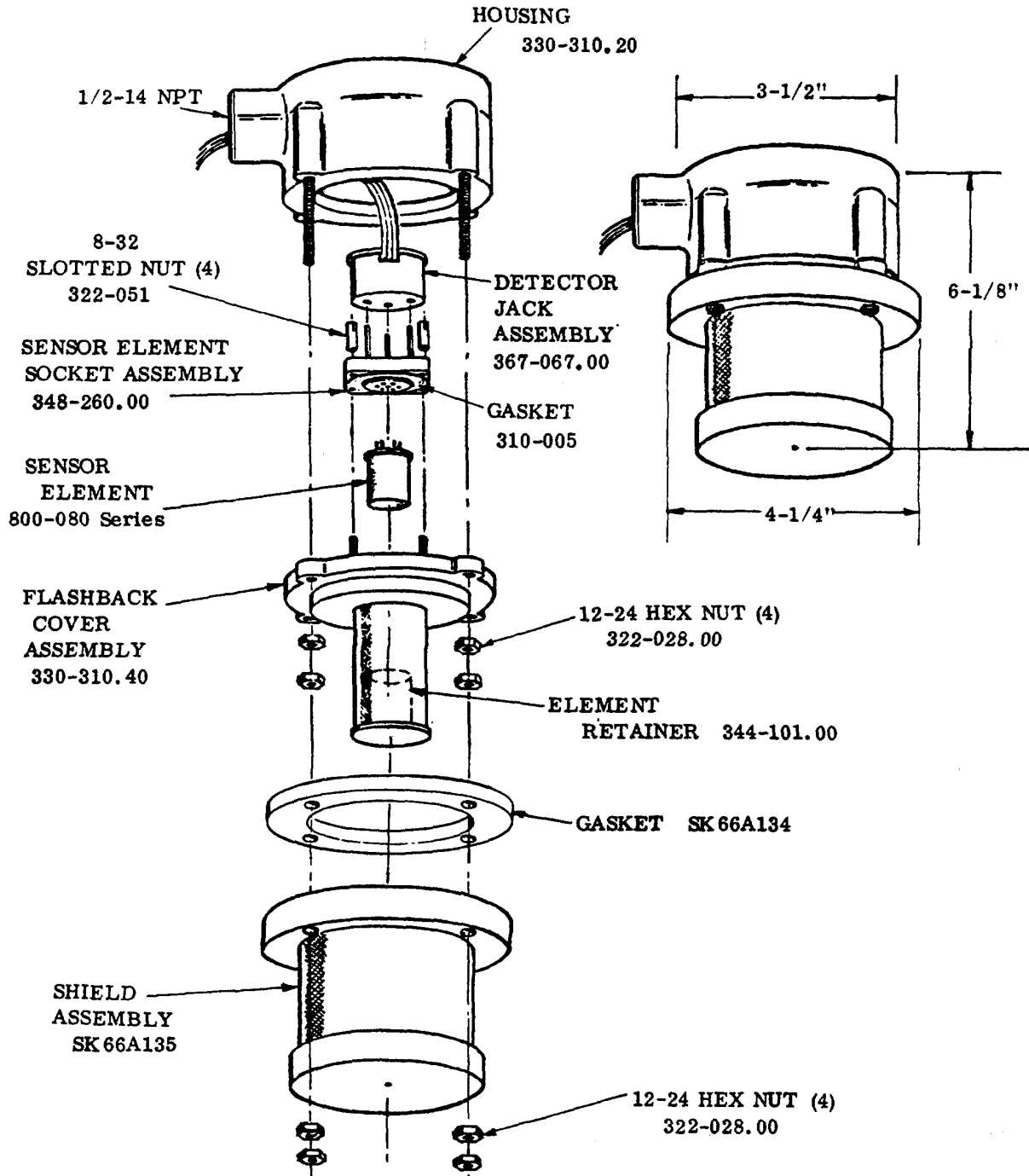

Figure 2-23. Detector Model 0023-7317 Exploded View

23-9617
7/1/76

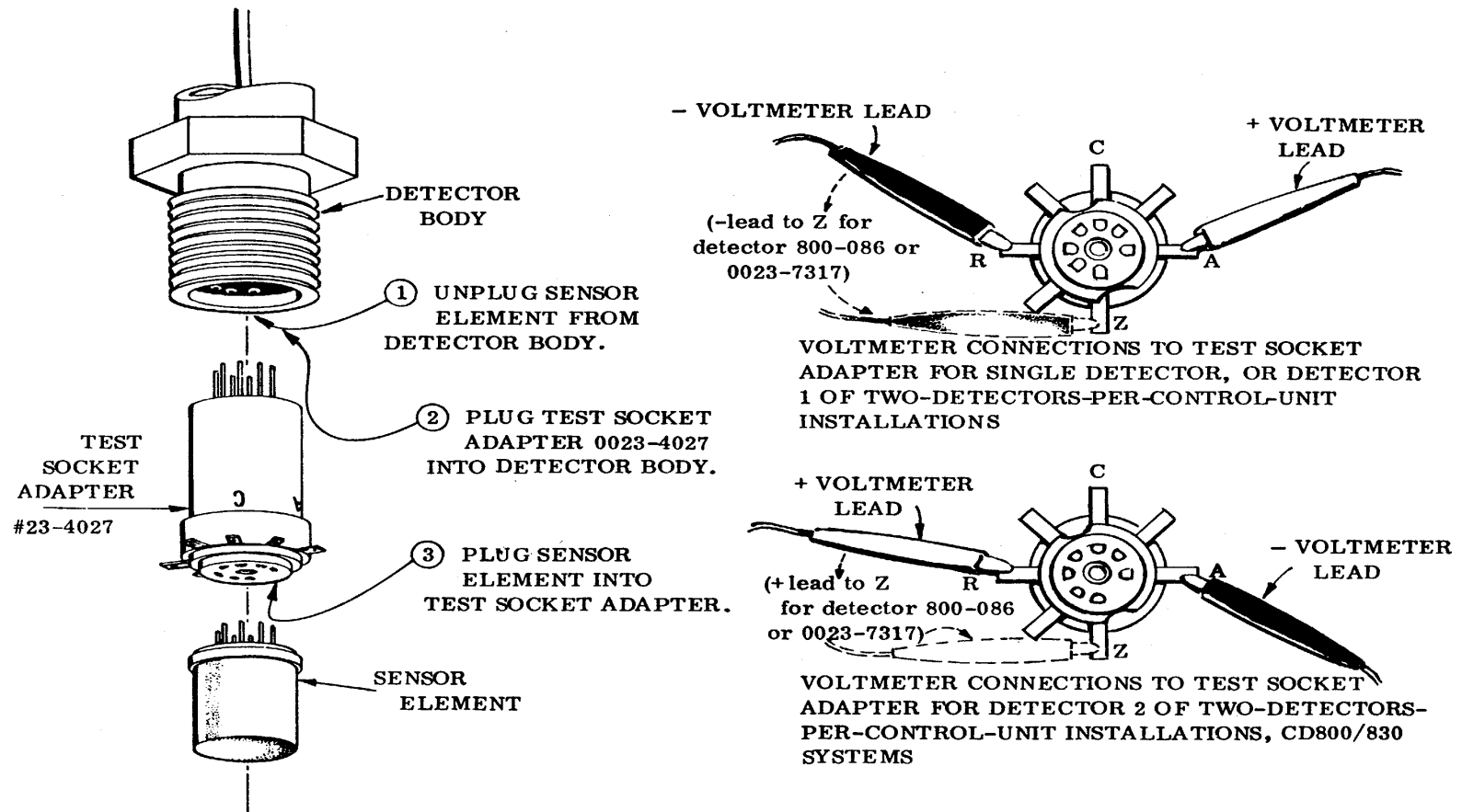

Figure 2-24. Use of Test Socket Adapter 0023-4027 to Determine Detector Operating Voltage

2-6.9 Testing Operating Voltages and Compensating For Conduit Wire Voltage Drops (continued)

4. If detector is a single detector operating from a control unit, or detector 1 of 2 (connected to DET 1 terminals) of CD800/830 system: Clip + lead of 0-10V range DC voltmeter to socket adapter terminal A and-lead of volt- meter to adapter terminal R (For detector 800-086 or 0023-7317 only: Clip + voltmeter lead to adapter terminal A and-lead to adapter terminal Z).

To test voltage of detector 2 where used with CD800/830 systems (detector connected to DET 2 terminals of control unit): Clip + voltmeter lead to socket adapter terminal R and-voltmeter lead to adapter terminal A (For detector 800-086 or 0023-7317 only: + voltmeter lead to socket adapter terminal Z and-lead to adapter terminal A).

5. Turn power off and gain access to CD830/832 unit potentiometer adjustment screws as follows:
 - a) Remove control unit from rack or cabinet and insert Circuit Card Extender #0023-4023 into rear terminal block. (Some models provide access to adjustment controls without use of card extender.)
 - b) Plug control unit into circuit card extender. (Card extender prevents any remote annunciation from operating during test or maintenance of the controller.)
6. Push PILOT ON/OFF pushbutton on control module front panel to switch power on (green PILOT light glows).
7. Using small screwdriver, adjust screw of VOLT potentiometer R2 on control module circuit board to obtain a reading of exactly 5.5 Volt (6.0 Volt for Natural Gas or Methane) on voltmeter clipped to detector test socket adapter terminals. Clockwise rotation of adjustment screw increases voltage. With two detectors operating from one control unit, it may be necessary to compromise in voltage setting, with one operating slightly above, the other slightly below recommended setting. The best performance, however, both should be within 0.05 volts of median recommended voltage.
8. Depress PILOT ON/OFF pushbutton on control module front panel to turn power off.
9. Remove test socket adapter from detector sensor socket and replace sensor element socket.
10. Reassemble detector, tightening all parts securely. (But do not at this point reinstall duct mounting detector #0023-4014 in duct.)

23-9617
4/15/77

2-6 DETECTOR INSTALLATION (continued)**2-6.9 Testing Operating Voltages and Compensating For Conduit Wire Voltage Drops . (continued)**

11. Obtain and record a voltage reading across red and black test points marked B on control module printed circuit board, for later use in maintenance.

2-6.10 DETECTOR CALIBRATION. Calibrate control module response to detector(s) in accordance with calibration procedures described in Section 3.**2-6.11 INSTALLATION OF PLUMBING FOR SAMPLE DRAWING DETECTOR ASSEMBLY #0023-4017 :** Installation of #0023-4017 detector (subsection 2-1) in areas where d fusion sampling is infeasible requires the following materials and equipment (Fig 2-25):

1. Source of compressed air at 10-15 psi.
2. ¼-inch tubing for inlet, compressed air, and exhaust lines; tubing material to be selected considering type of sample to be drawn.
3. Flowmeter and metering valve.
4. In some installations: in-line moisture trap(s) at low point in run laid to grade.
5. Recommended for maximum reliability: differential pressure switch to indicate alarm in response to flow failure.

Install inlet tubing so that line length does not exceed 100 feet (to keep response time short). Install exhaust line as short as possible to minimize back pressure. When the gases being sampled are at an elevated temperature, the detector and sample lines should be maintained above the "dewpoint" of the vapors being sampled to avoid condensation. Install the detector assembly and sample lines as close as possible to the heated source. If contact with the heat source is not possible, the sample line and reaction chamber should be heated-traced with steam or electrical heaters as desired.

2-7 WARNING AND ALARM CIRCUIT MODIFICATIONS

As manufactured, each control module is provided with a RESET pushbutton

23-9617
7/1/76

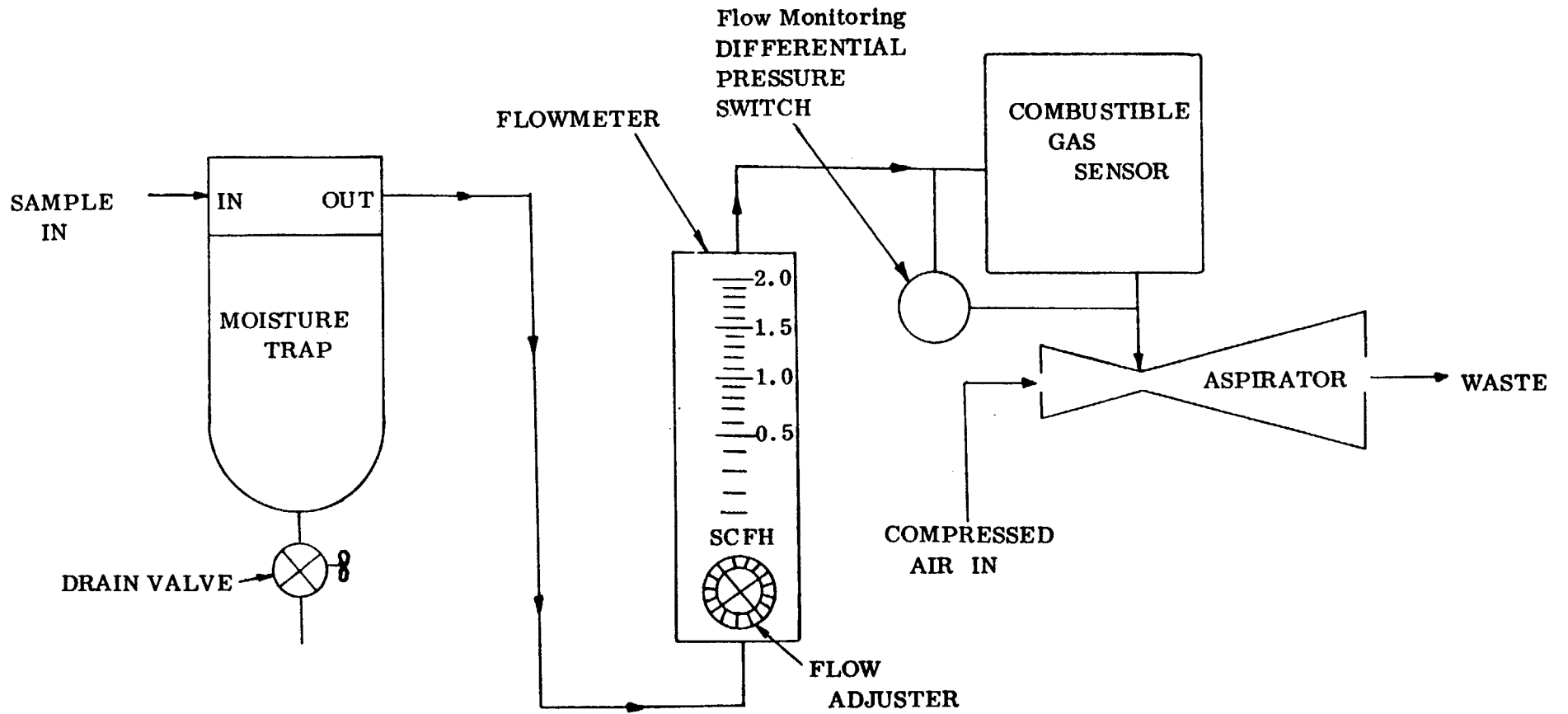

Figure 2-25. Recommended Sample Flow Connections

2-7 WARNING AND ALARM MODIFICATIONS (continued)

and circuitry for the manual resetting of warning and alarm circuit relays that have been energized in response to emergency gas conditions or tests. Further, WARN or ALARM light circuits operate to turn on the lights in response to emergency conditions whether the relay will operate or not. These modes of operation assure that attention will be directed to the exact location of an emergency condition and that a visual indication of an emergency will appear on the module front panel even if a warning or alarm delay should fail.

For installations where other modes of operation have special advantages, on-site modification of control module circuitry can provide the following optional modes:

- Manual resetting of warning and alarm relays by means of one switch common to several modules.
- Automatic resetting for both warning and alarm relays.
- Automatic resetting for either warning or alarm relays.
- Warning and alarm relays not energized during TEST (to prevent activation of external devices such as sprinkler systems, process control mechanisms, etc.

Instructions for each of the above modifications appear in the following paragraphs. (Refer to Figures 2-26, 2-27, and 2-28.)

2-7.1 MODIFICATION FOR COMMON POINT RESETTING OF CD830 MODULES : To modify warning and alarm circuits of two or more CD830 modules for manual resetting from a common point:

1. Remove each module from enclosure or housing. CD800W and CD802W: unlatch and swing front panel to open position.
2. Using small wire cutters, cut white/gray wire connected to pin 1 of CD800/830 alarm light socket or white/black wire at pin 2 of CD802/832 alarm light socket. Tape cut end of wire to avoid short circuits.
3. Grasp red ALARM/RESET lens with fingers and pull to extract from module front panel.

23-9617
5/15/78

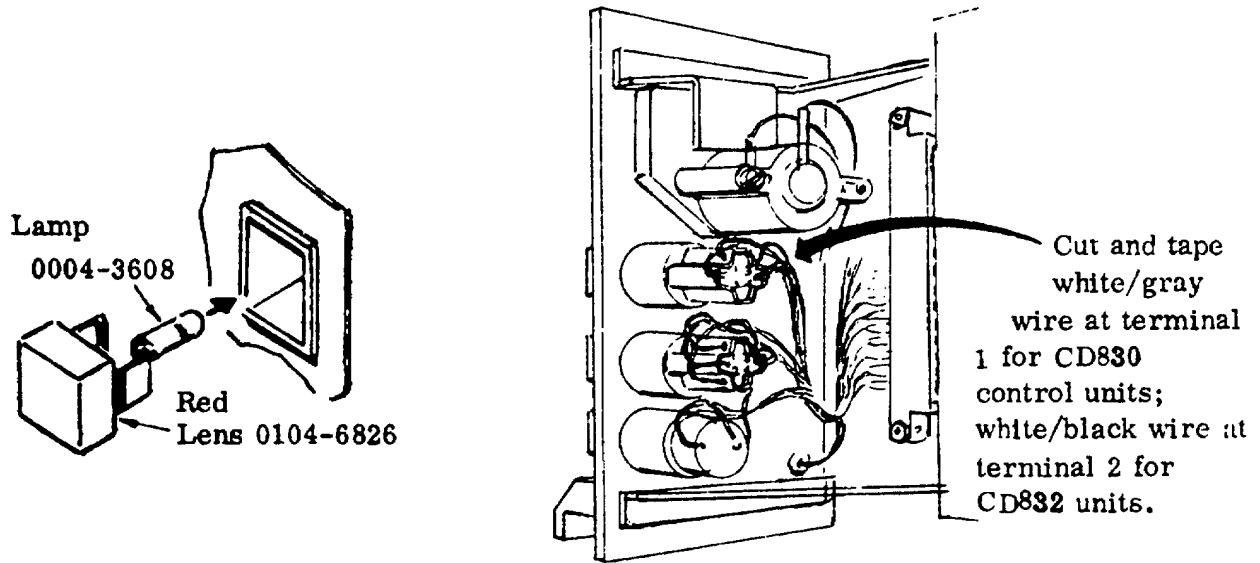

Figure 2-26. Lamp Lens Replacement, CD830/832

Figure 2-27. Modification Point for Warn and Alarm Automatic Reset

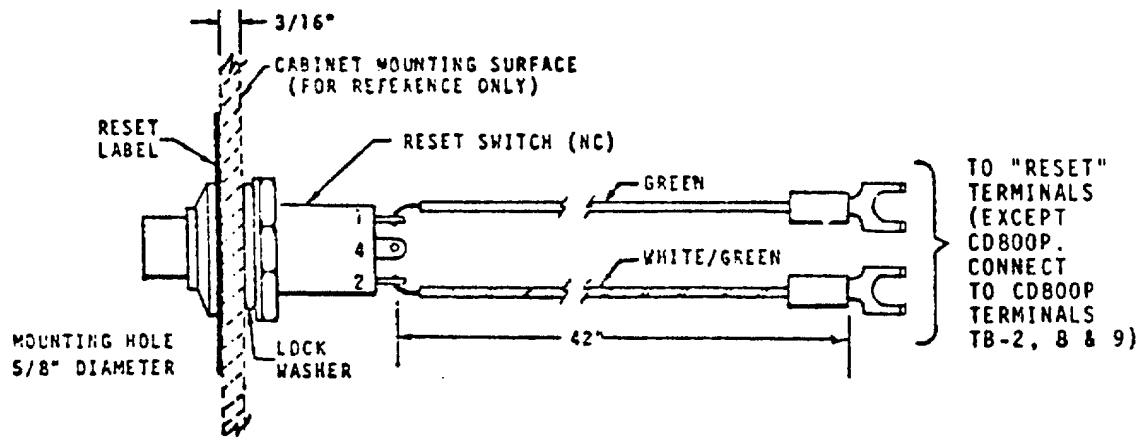

Figure 28. #0023-4080 Reset Switch with Mounting Hardware and Wiring

23-9617
5/12/78

2-7 WARNING AND ALARM CIRCUIT MODIFICATIONS (continued)

2-7.1 Modification For Common Point Resetting (continued)

4. Insert replacement lens into lens socket on front panel of module (except CD800X enclosure).
5. Reinstall module in housing or enclosure.
6. Mount RESET switch on enclosure door, housing panel, remote control console panel, or whenever desired.

NOTE: J-W Conversion Kit #0023-4080 provides a pushbutton switch mounting in 5/8-inch-diameter hole, RESET label, and 42-inch wiring harness. Lacking this, any SPST-NC momentary contact switch will serve. (Figure 2-28.)

7. Connect two wires from switch to RESET terminals on enclosure or housing terminal strip (CD800P: Terminals TB-2, 8 and 9).
8. Connect RESET terminals of all modules in parallel with RESET terminals of first module.

2-7.2 MODIFICATION FOR AUTOMATIC RESET. Modify control unit printed circuit boards for automatic resetting of warning and/or alarm circuitry after a circuit-triggering gas condition has cleared as follows:

2-7.2.1 To modify CD802 and CD832 control units for automatic resetting:

1. Remove diodes from control unit printed circuit boards as follows:
 - a. For automatic resetting of warning circuitry only (retaining manual alarm circuitry resetting): Clip leads of diode CR25 and remove diode.
 - b. For automatic resetting of alarm circuitry only (retaining manual warning circuitry resetting): Clip leads of diodes CR21 and CR22 and remove diodes.
 - c. For automatic resetting of both warning and alarm circuitry: Clip leads of diodes CR25, CR21, and CR22 and remove diodes.
2. If both warning and alarm functions are modified for automatic resetting: With fingers, grasp and withdraw RESET lens from socket and replace with unlabeled red lens 0104-6826. If manual resetting is retained for either warning or alarm circuitry, do not replace the RESET lens.

23-9617
5/15/78

2-7.2.2 To modify CD800 and CD830 control units for automatic resetting:

1. Remove diodes from control unit printed circuit boards as follows:
 - a. For automatic resetting of warning circuitry only (retaining manual alarm circuitry resetting): Clip leads of diode CR3 and remove diode.
 - b. For automatic resetting of alarm circuitry only (retaining manual warning circuitry resetting): Clip leads of diode CR2 and remove diode.
 - c. For automatic resetting of both warning and alarm circuitry: Clip leads of diodes CR2 and CR3 and remove diodes.
2. If both warning and alarm functions are modified for automatic resetting:

CD830 only: Grasp RESET lens with fingers and withdraw from socket. Replace with unlabeled red lens 0104-6286. (Unlabeled red lens is standard for CD800W control unit front panels.) If manual resetting is retained for either warning or alarm circuitry, do not replace the CD830 RESET lens.

2-8 INSTALLATION OF EXTERNAL ACCESSORY DEVICES

The CD800/830 module provides terminals for accessory devices such as chart recorders, remote alarms, relays, and switches. Instructions for installation of these accessories are contained in the following paragraphs.

2-8.1 INSTALLATION OF RECORDER. Connect recorder as follows: Individual control modules are compatible with 0-100 mV recorders having an input impedance greater than 100 ohms.

NOTE: A multipoint recorder used to scan outputs from several modules must have a non-shortening commutator (selector switch) to avoid momentary connecting of two module recorder signal outputs together.

1. Connect recorder to REC + and - terminals on module terminal panel (CD800P: to terminals TB-2, 4(-) and 5 (+)).
2. Press and hold down TEST pushbutton. If necessary, adjust RANGE control R22 for full-scale meter deflection.
3. Observe recorder response at full-scale meter reading at control module.

23-9617
3/16/79

4. Turn screw adjustment of RECORDER potentiometer R17 to set recorder response at desired 100% point of recorder graph.

2-8.2 INSTALLATION OF REMOTE RESET SWITCH. To install remote reset switch, follow Modification for Common Point Resetting, paragraph 2-7.1.

2-8.3 INSTALLATION OF REMOTE ALARM AND PROCESS CONTROL DEVICES. Buzzers, lights, horns, process control mechanisms and other external devices rated up to 3 amperes maximum at 30 VDC/120 VAC for resistive loads (derated to 50 percent for inductive loads) may be connected directly to WARN, ALARM, or FAIL terminals on the control module terminal panel. Devices requiring heavier load current must be isolated from control module circuitry by means of external relays to prevent destruction of printed circuit traces.

Tables 2-3 and 2-4 identify the various combinations of relay switching terminals available for operating remote devices.

2-8.4 "HORN SILENCE" OR "ACKNOWLEDGE" OPTION. In some cases where signal horns or sirens are connected to a system, it may be undesirable to have such signals continue to sound once they have alerted personnel to the presence of a hazardous situation. In such cases, an accessory is available from the factory to permit the signal device to be acknowledged and the sound silenced while corrective action is implemented, even though the condition persists and the "Warn" and "Alarm" relays remain actuated. At the same time, it is desirable to have the signal device remain armed to report a change in status, such as another "Warn" or "Alarm" condition at a new location, which may indicate a worsening condition. This option may be readily provided at the factory when ordered in multi-point installations, and is available in kit form for addition to existing systems. (For add-on installation, it is recommended that specific requirements be discussed with a Bacharach representative.)

This arrangement consists of a number of "Trigger Modules" appropriate to the number of detection channels with which it is to work (each trigger module accepting six channels of "Alarm" or "Warn" output), a common output auxiliary relay, a common "Silence" or "Acknowledge" pushbutton switch, and a horn or other signal device. When the horn sounds in response to a "Warn" or "Alarm" signal, it may be manually silenced by pressing the "Acknowledge" pushbutton; however, a new "Warn" or "Alarm" condition at another location will cause the horn to sound again, and to continue to sound until acknowledged again. This process may be repeated until all locations have reported an alarm and been acknowledged, at which point the circuit is saturated, having done all it can. However, this circuit will be automatically re-armed whenever a condition causing an alarm has cleared and output circuits reset (either automatically or manually). This circuit is shown in Figure 2-29.

Part numbers are: Trigger module, #0051-7106; Power module, #0051-7101; Relay assembly, #0051-7102.

23-9617
10/22/80

Table 2-3. Relay Switching Terminals for External Devices, Excepting CD800P and CD802P

RELAY SWITCH POSITION			
	Normally OFF; turned ON during alarm condition	Normally ON; turned OFF during alarm condition	External power HOT wire to:
Warn (low alarm) terminals	8	9	7
	11	12	10
Alarm (high alarm) terminals	2	3 (CD802/832: Channel 1 only)	1
	5	6 (CD802/832: Channel 2 only)	4
Fail terminals	15	14	13

NOTE: Complete external circuits with wire from external device to external power neutral connection.

Table 2-4. Relay Switching Terminals for External Devices, Models CD800P and CD802P Only

RELAY SWITCH POSITION			
	Normally OFF; ON during alarm condition	Normally ON; OFF during alarm condition	External power HOT wire to:
Warn (low alarm) terminals	TB-1, Terminal 8	TB-1, Terminal 9	TB-1, Terminal 7
	TB-2, Terminal 11	TB-2, Terminal 12	TB-2, Terminal 10
Alarm (high alarm) terminals	TB-1, Terminal 2 (CD802P: Channel 2 only)	TB-1, Terminal 1	TB-1, Terminal 3
	TB-2, Terminal 5 (CD802P: Channel 1 only)	TB-2, Terminal 6	TB-2, Terminal 4
Fail terminals	Terminal 15	Terminal 14	Terminal 13

23-9617
3/19/79

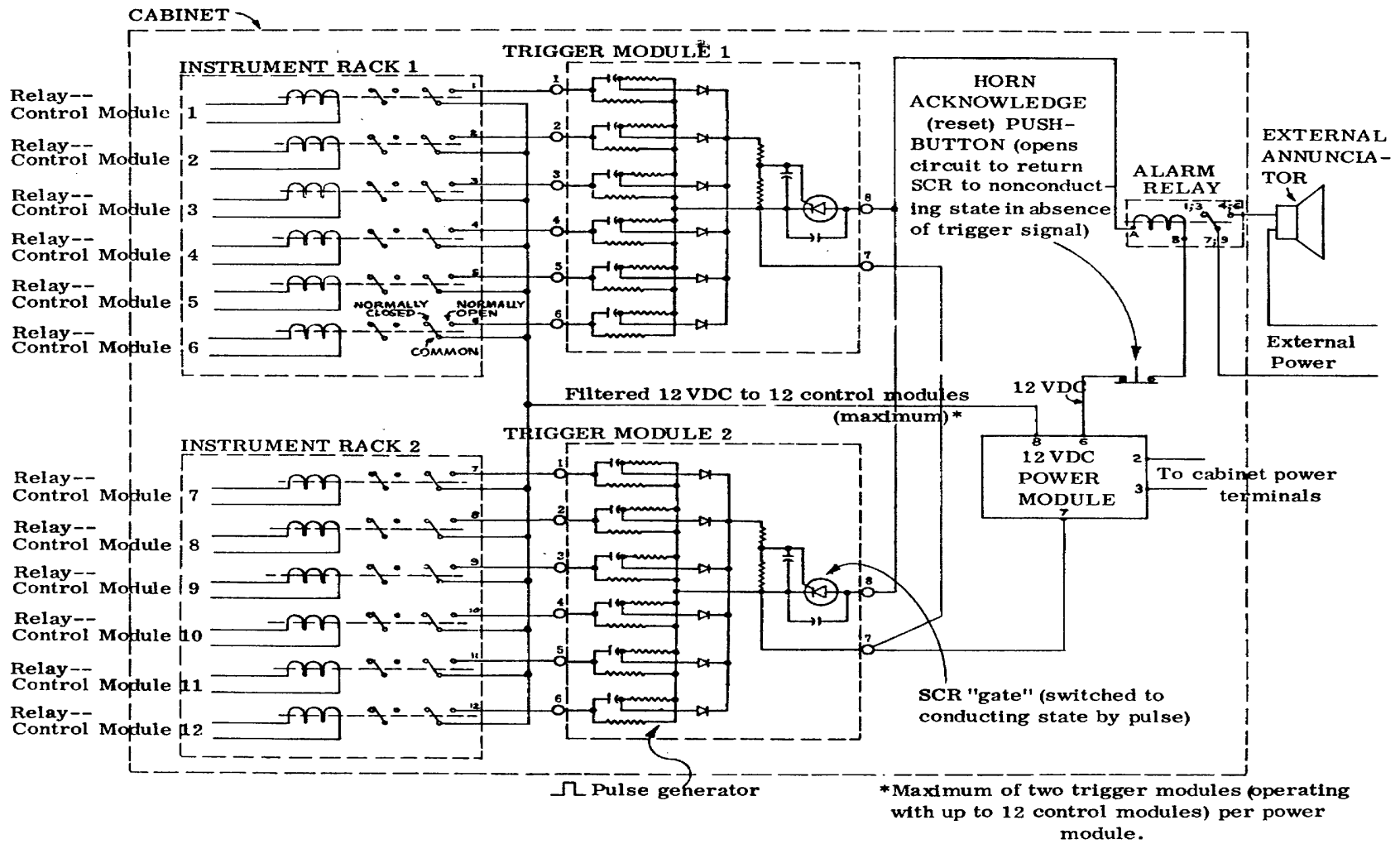

Figure 2-29. Typical Recurring Alarm Circuitry (Optional)

SECTION 3CALIBRATION AND ADJUSTMENTS3-1 GENERAL OBJECTIVES

In general, CD800/830 and CD802/832 calibration consists of setting ZERO and GAIN adjustments on the control module so that 0 to 100% L. E. L. gas-air mixtures at the detector drive the control module meter indicator between 0 to 100% readings. Because each specific combustible gas releases energy upon oxidation at a different rate than another, different gases require different calibrations. After calibration has been completed, control module WARN and ALARM potentiometers may be adjusted to switch warning and alarm relays in response to designated % L. E. L. gas-air mixture levels at the detector. Then a RANGE potentiometer is set to drive the meter indicator full-scale when the TEST pushbutton is depressed, and a RECORD potentiometer may be adjusted to operate a recorder at desired voltage levels.

3-2 CALIBRATION

Calibration procedures are required for three different alarm system applications:

1. Individual detectors (CD800/830 or CD802/832).
2. Detectors paired with one CD800/830 control unit.
3. One or two detectors per control unit sampling volatile hydrocarbons with flash points below 700 F.

Select and follow the procedure appropriate to the existing system.

NOTE: New installations and operating installations with new detectors should be rezeroed with no combustible gas at detectors after 24 hours of operation and again after 1 week of operation.

3-2.1 CALIBRATING A SYSTEM WITH ONE DETECTOR PER CD800/830 CONTROL UNIT OR INDIVIDUAL DETECTOR OF CD802/832 TWO-CHANNEL CONTROL UNIT. Two people and the following special tools are required to calibrate the gas alarm system:

Portable Combustible Gas Indicator

23-9617
4/6/77

3-2 Calibrating a System with One Detector per CD800/832 Control Unit or Individual Detector of CD802/832 Two-channel Control Unit (continued)

- J-W Gas Calibration Kit (0023-7260) or Bacharach Professional Calibration Kit (51-7070; Instruction 51-9001)
- Sample cup (#347-095 for detectors 800-086, 0023-7317, 0023-4014, and 0023-4017; or #0023-4098 for detectors 0023-4012)
- Gas Calibration Cylinder (either 100-percent nitrogen, #0023-4003, or Zero-gas/dry-air, #0023-4004) or Professional Calibration Kit 51-7070 operating in clean-air mode if combustible-gas-free air does not exist at the detector
- Gas Calibration Cylinder containing sample gas equivalent to gas expected at detector location if Calibration Kit 0023-7260 is used, or Professional Calibration Kit 51-7070 with self-contained sample gas cylinder

Perform sampling and adjustment procedures for calibration as follows:

NOTE: CD800/830 and CD802/832 systems will not operate properly unless the remote detector voltage is first set. Voltage setting should be checked and readjusted, if necessary, each time a detector element is replaced. (Refer to Section 2-6. 7 for specific instructions for voltage measurements.)

1. If necessary, turn meter mechanical screw adjustment to set indicator needle to zero on meter scale (this adjustment with power off).
2. Turn power on at control unit and operate detector for at least five minutes before calibrating.
3. Using a portable combustible gas indicator, test air at detector. If air is free of combustible gases, go on to step 4. If air is not free of combustible gases, or if portable test instrument is not available, apply J-W Zero Gas Dry Air, J-W 100-percent nitrogen gas, or clean air from Bacharach Professional Calibration Kit 51-7070 (per kit instructions 51-9001) as follows:
 - a. If using J-W Gas Calibration Kit 0023-7260 together with appropriate sample cup and gas calibration cylinder (0023-4003 100% Nitrogen or 0023-4004 Zero Gas/Dry Air), attach regulator assembly kit to gas cylinder. Close regulator valve and attach hose and sample cup to regulator (Figure 3-1). If using Professional Calibration Kit 51-7070, follow kit instructions to apply clean air output of kit to detector.
 - b. Place sample cup over detector (Figure 3-1).
 - c. If using Zero Gas/Dry Air or 100% Nitrogen cylinder, open regulator valve to fill cup with sample gas and displace air.
4. Turn adjustment screw of ZERO potentiometer on control unit printed circuit board (CD800/830: R24; CD802/832: Channel 1: R9, labeled 21; Channel 2: R13, labeled 22) as necessary to set meter indicating needle a zero reading on meter scale.

23-9617
4/6/77

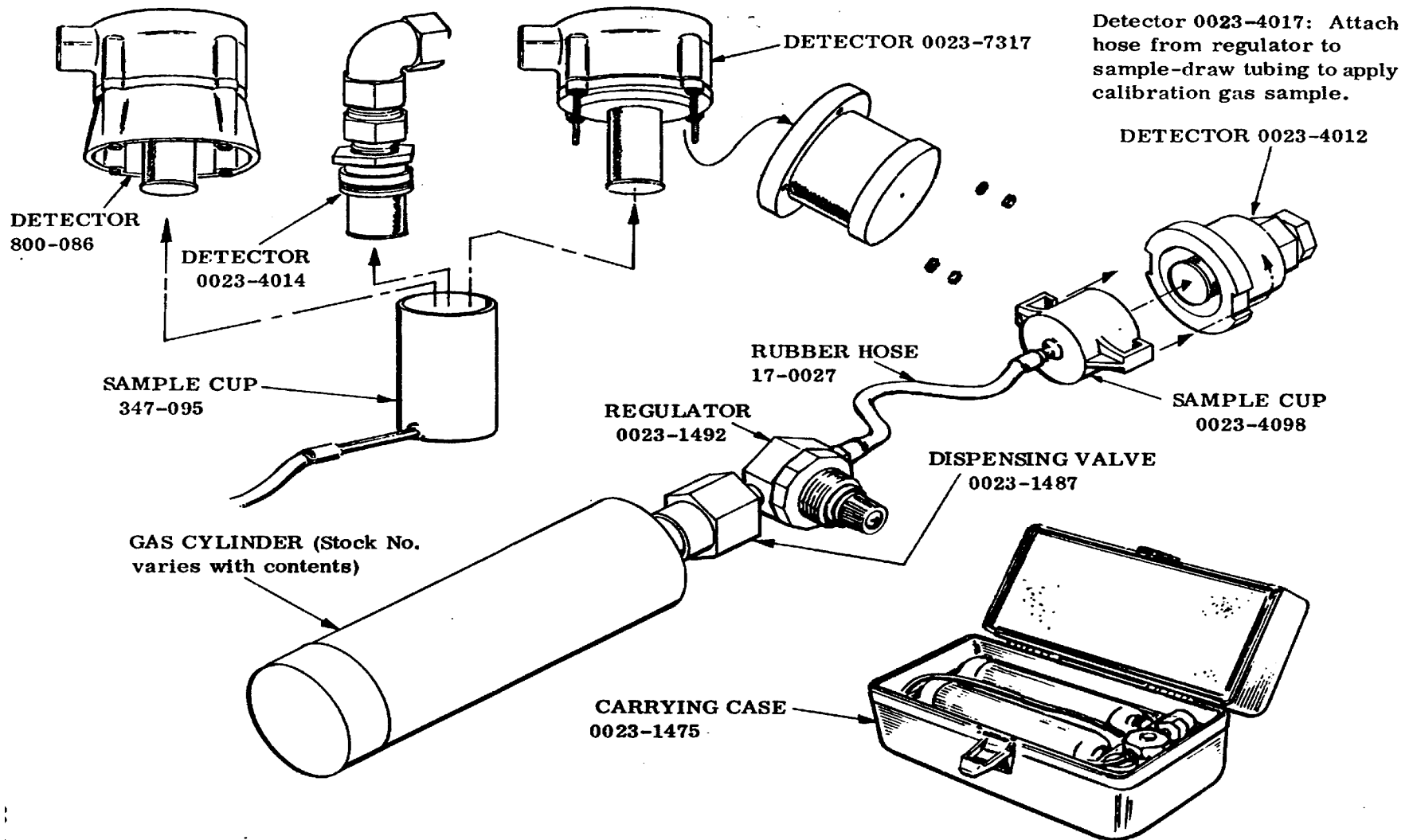

Figure 3. Use of Test Kit (0023-7260) Dispensing Valve and Regulator Assembly, Gas Cylinder, and Sample Cup(s) at Diffusion Detectors for System Calibration Test

3-2.1 Calibrating a System with One Detector per CD800/832 Control Unit or Individual Detector of CD802/832 Two-channel Control Unit (continued)

5. Using J-W Gas Calibration Kit 0023-7260 or Professional Calibration Kit 51-7070, expose detector to sample gas of known concentration until meter reading stabilizes.

If desired, known concentrations of propane gas may be used to calibrate gas detection systems for correct response to gases other than propane as follows:

- a. On conversion chart (Figure 3-2) horizontal scale for "% L. E. L. GAS, " find point representing known percent L. E. L. concentration of propane gas sample applied. For example: The standard J-W gas cylinder contains 1 percent propane by volume in air, a concentration known to be at 46 percent L. E. L.--for which the 46-percent point on the horizontal scale at the bottom of the chart would be selected.
- b. Follow up from the selected percent point vertically to diagonal line representing gas for which calibration is wanted.
- c. From point found on diagonal line, follow horizontally to left and read percent L. E. L. meter reading on vertical "% L. E. L. METER READING" scale. To continue the example: Following up from the 46 percent point of the horizontal scale to the diagonal line representing ethylene oxide, and then following from the point on the diagonal to the vertical scale at left indicates a percent L. E. L. meter reading of approximately 50 percent for ethylene oxide gas calibration.

For gases that are not represented on the chart of Figure 3-2, the multiplying (K) factors in Table 3-1 may be used to calibrate with propane for gases other than propane. Or the multiplying factors may be used as a preferred alternate method to use of the chart. For example, to use J-W standard propane gas cylinder 0023-4009 (1 percent by volume; 46 percent L. E. L.), multiply 46 by the ethylene oxide multiplying (K) factor of 1.09 as shown in Table 3-1, and get 50 percent as calculated percent L. E. L. reading for ethylene oxide. If using the Professional Calibration Kit 51-7070, multiply kit percent L. E. L. output (determined per instructions with kit) by the multiplying factor for the gas for which calibration is desired.

6. While continuing exposure of detector to sample gas, adjust GAIN potentiometer (on CD800/830 circuit board: R10; on CD802/832 circuit board: R7 for Channel 1 and R18 for Channel 2) so that meter reading matches percent L. E. L. concentration of sample gas or percent equivalent for another gas.

Recommendation: For safety factor, adjust GAIN potentiometer to obtain meter reading 10 percent higher than known concentration of applied sample gas.

23-9617
4/4/78

*Based on Lower Explosive Limit of gases at normal room temperature (L E L decreases with increases in temperature.)

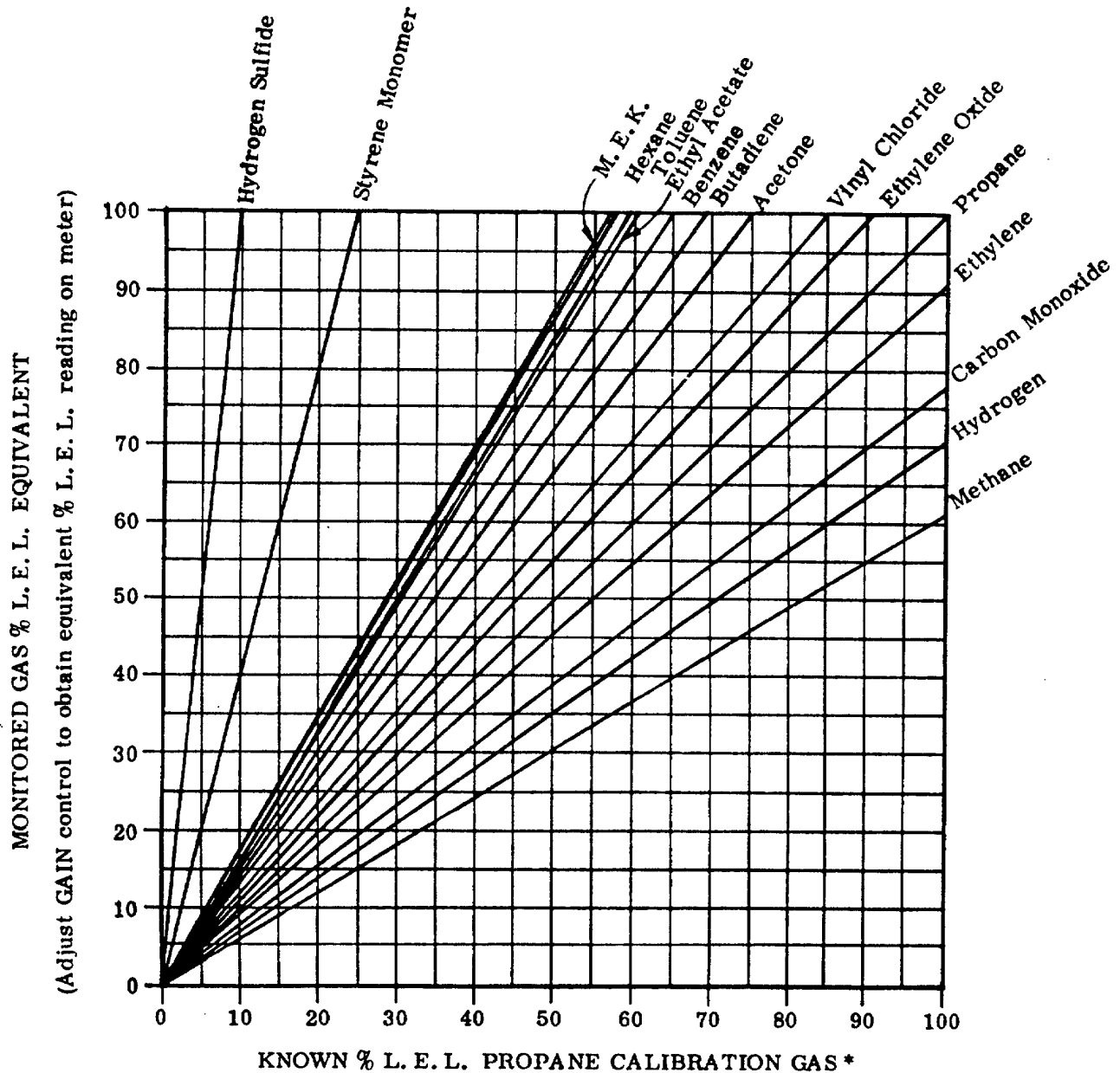

(On selected gas curve, find point over horizontal scale representing known % L.E.L concentration of propane gas sample. Read vertical scale at left of determined point to find % L.E.L. equivalent for actual gas to be monitored.)

Note: Series 800 detector sensor elements with different model numbers differ in response to some combustible gases and vapors. Consult Table 5-1 to determine the gases and vapors to which a given sensor element may be expected to respond.

Figure 3-2. Calibration Percent L. E. L. Equivalents for Gases Other Than Propane, with Propane Used as Calibrating Gas

23-9617
6/21/77

3-2.1 Calibrating a System with One Detector per CD800/832 Control Unit or Individual Detector of CD802/832 Two-channel Control Unit (continued)

TABLE 3-1. Multiplying (K) Factors for Conversion of Propane Gas % L. E. L. to % L. E. L. Readings for Other Gases *

Acetone	1.32	Hydrogen Sulfide	8.30
Acetylene	1.37	Isopropyl Alcohol	1.49
Acrylonitrile	0.97	Methane	0.60
Benzene	1.50	Methyl Alcohol	1.06
Butadiene	1.45	Methyl Acrylate	1.86
Butane	1.04	Methyl Chloride	0.71
Butyl Acetate	2.29	Methyl Chloroform	3.5
Carbon Disulfide	8.32	Methyl Ethyl Ketone	1.74
Carbon Monoxide	0.77	o-Xylene	2.98
Cyclohexane	1.49	Pentane	1.34
Ethane	0.75	Perchloroethylene	26.3
Ethyl Acetate	1.63	Propylene	1.22
Ethyl Alcohol	1.10	Propylene Oxide	1.40
Ethylene	0.90	Styrene Monomer	3.95
Ethylene Oxide	1.09	Tetrahydrofuran	1.32
Ethyl Ether	1.30	Toluene	1.66
Heptane	1.90	Trichloroethylene	0.99
Hexane	1.72	Vinyl Acetate	1.44
Hydrogen	0.70	Vinyl Chloride	1.17

*Based on Lower Explosive Limit of Gases at normal room temperature. (L.E.L. decreases with increases in temperature.)

- If using J-W Calibration Kit 0023-7260, close regulator valve on cylinder and remove sample cup from detector. (Meter reading should return to zero.) Disassemble sampling kit components and replace in kit. Store sample gas cylinder in cool area when not in use. If using Professional Calibration Kit 51-7070, follow kit instructions for shutdown.

NOTE: If detector cannot be calibrated by following the above procedures, refer to Section 4, Chart 4-1E, Troubleshooting Procedures.

- After 24 hours of operation, confirm that meter reading indicates zero in absence of combustible gas. If necessary, readjust reading to zero (as in step 4). Repeat readjustment, if necessary, after one week.

3-2.2 CALIBRATING A SYSTEM WITH TWO DETECTORS PER CD800/830 CONTROL UNIT. The following special tools are required to calibrate a paired detector system:

- Portable Combustible Gas Indicator
- 2 J-W Gas Calibration Kits (0023-7260) or Professional Calibration Kits (51-7070) (1 if fresh air is assured at both detectors)
- 1 or 2 Sample Cups (Figure 3-1)

23-9617
6/21/77

3-2.2 Calibrating a System with Two Detectors per CD800/830 Control Unit (continued)

If using J-W Calibration Kit(s) 0023-7260: 2 Gas Calibration Cylinders: Either 100% Nitrogen (0023-4003) or Zero Gas/Dry-air (0023-4004) if combustible-gas-free air does not exist at both detectors (one or none required if one or both detectors are in fresh air. If Professional Calibration Kit(s) (51-7070) is used, kit supplies clean, filtered air for zero calibrations.

If using J-W Calibration Kit 0023-7260: Gas Calibration Cylinder containing sample gas similar to that expected at detector locations. If using Professional Calibration Kit 51-7070: Kit supplies sample gas at known percent L. E. L. concentration.

0-10 Volt range D. C. voltmeter with $\pm 2\%$ accuracy in 5-6 Volt range.

Test Socket Adapter 0023-4027

Circuit Card Extender 0023-4023 (except for CD800P models with built-in extension feature)

Calibrate CD800/830 paired-detector alarm system for zero meter indication in gas-free air as follows:

1. Read supply voltages at both detectors (using test socket adapter and voltmeter in accordance with instructions in Section 2-6.7.
2. If supply voltages are not within ± 0.15 VDC at both detectors, find and correct faulty circuit conditions (poor connections, leakage, open or short circuits, unbalanced resistances in supply lines due to wrong choice of wire gauges for length of run). Remove test socket adapter(s) and reinstall sensor elements in detector socket(s).
3. Using portable combustible gas indicator, test surrounding air at both detectors. If combustible gases are present at one or both detectors, use J-W gas calibration kit(s), sample cup(s), and 100% Nitrogen or Zero-gas/Dry-air cylinder(s), or Profession Calibration Kit(s) 51-7070 to supply combustible, gas-free air (paragraph 3-1.1, Figure 3-1, and Professional Calibration Kit instructions 51-9001).

NOTE: Both detectors must be sampling zero combustible gas before adjustment of indicating meter circuitry for zero meter setting.

4. For access to control unit screw adjustments in many rack and cabinet installations, remove circuit board, plug circuit card extender #0023-4023 into connector strip at rear, and plug circuit board into card extender. Use of the card extender during circuit adjustments prevents remote alarms from operating.

23-9617
4/6/77

3-2 CALIBRATION (continued)3-2.2 Calibrating a System with Two Detectors per CD800/830 Control Unit. (continued)

5. Turn screw adjustment of ZERO potentiometer R24 on control module printed circuit board to set meter indicator to zero on meter scale.
6. If meter indicator cannot be set to zero, disconnect detector 2 at the control module and install a set of 15-ohm resistors across DET 2 A-C-R terminals. If meter indicator can not be adjusted to zero with one operating detector, probably the response characteristics of the paired sensor elements are too dissimilar while both are operating. (One element may have been long in use and the other new.)
7. If necessary, replace old sensor element, reconnect detector 2 to control module, and adjust ZERO potentiometer R24 to set meter indicator to zero on meter scale.

After meter indicator has been set to zero, calibrate paired detectors to co-ordinate meter indicator percent L. E. L. deflection range with detector response to gas as follows:

1. Apply sample gas of known concentration from J-W gas calibration cylinder or Professional Calibration Kit 51-7070 to one detector. Second detector must be simultaneously sampling zero combustible gas.
2. Turn adjustment screw of GAIN potentiometer R10 on control module circuit board until meter reading matches percent L. E. L. concentration of gas specified on sample gas cylinder label or produced by Professional Calibration Kit 51-7070.
3. Remove sample gas from first detector. Confirm that meter returns to zero in response to fresh air. Expose second detector to sample gas. Compare meter reading with first reading taken. Do not readjust GAIN control R10. If readings differ more than ± 10 percent of the L. E. L. reading, replace sensor element in detector with lowest reading and repeat ZERO and GAIN adjustment procedures, following steps 1 and 2 above.

23-9617
4/14/77

3-2 CALIBRATION (continued)3-2.2 Calibrating a System with Two Detectors per CD800/830 Control Unit. (continued)

4. Record meter responses to each detector to aid in evaluating future performances of the detectors.

3-2.3 CALIBRATING A SYSTEM FOR VOLATILE HYDROCARBONS WITH FLASH POINTS BELOW 70°F. The following materials are required to calibrate a detector/module system for response to volatile liquid vapors:

Graduated pipette, 0-1 ml (lcc).

One-gallon jug with cap

Piece of aluminum foil

Thermometer

Sample of volatile liquid

Calibrate detector/module system for response to volatile liquid vapors as follows. Before exposing detector to sample mixture, confirm that meter reads zero with detector sampling fresh air. Adjust ZERO control R24 of CDS00/830 Systems, or Channel 1 Z1 (R9) and Channel 2 Z2 (R13) of CD802/832 Systems, if necessary.

1. Using pipette, drop 0.2cc of liquid from which vapors are to be detected in a one-gallon jug. Place aluminum foil on jug to aid in mixing vapor in air.
2. Cap jug and agitate until liquid has completely evaporated and vapor has diffused.

NOTE: Benzene, toluene, hexane, and xylene may take up to half an hour to evaporate and diffuse.

3. Remove cap and place mouth of jug over detector. Invert jug if position of detector permits, since vapors of all flammable liquids are heavier than air.
4. Note reading on module indicating meter after 45 seconds. Reading should approximate percent L. E. L. value for same liquid at temperature of 70°F as listed in Table 3-2. (Heat or cool vaporizing jug to thermometer reading 70° for testing.)
5. Adjust GAIN potentiometer R10 on control module circuit board to move meter indicator to read on scale at approximate Table 3-2 value.

23-9617
7/1/76

<u>MATERIAL</u>	<u>% L. E. L. at 700F.</u>
Acetone	66
Allyl Alcohol	75
Ethyl Alcohol	67
Methyl Alcohol	47
Benzene	111 (Use 0.1 cc for 56% L. E. L.)
Ethyl Ether	65
Methyl Ethyl Ketone	79
Methyl Isobutyl Ketone	72
n-Heptane	80
n-Hexane	89
n-Pentane	75
Toluene	100
o-Xylene (Flash point 90° F)	104 (Use 0.1 cc for 52% L. E. L.)

Table 3-2. Percent L. E. L. Reading with 0. 2 cc Vaporized Volatile Liquid in One Gallon of Air.

23-9617
4/14/77

3-2.3 CALIBRATING A SYSTEM FOR VOLATILE HYDROCARBONS WITH FLASH POINTS BELOW 700 F (continued)

NOTE: The % L. E. L. reading for compounds other than those listed in Table 3-2 may be calculated by using the following formula:

$$\text{Reading} = \frac{\text{Specific Gravity} \times 12,760}{\text{Molecular Weight} \times \text{L. E. L.}}$$

Example: n-Pentane molecular weight = 72.15

$$\text{Reading: } \frac{634 \times 12,760}{72.15 \times 1.5} = 75\% \text{ L. E.L.} \quad \text{specific gravity} = .634$$

3-3 ADJUSTMENTS

With % L. E. L. meter response properly adjusted for the specific detector element type and kind of combustible gas monitored, adjust warning, alarm, test, and recording circuits to operate at the desired voltage levels in accordance with the following procedures.

3-3.1 WARNING CIRCUIT ADJUSTMENT. Adjust warning circuit to operate at the voltage level representing a specified % L. E. L. gas-air mixture as follows:

NOTE: If FAIL light comes on during adjustment operations, wait 45 seconds after FAIL light goes out so that time delay circuit will not interfere with continuing adjustments.

1. To impress a warning level triggering signal on the warning circuit, turn ZERO potentiometer adjustment screw (R24 for CD800/830, R9, labeled Z1, for Channel 1 or R13, labeled Z2, for Channel 2 of CD802/832 Systems) slowly clockwise until warning relay K1 energizes and WARN light goes on (circuit card extender circuitry prevents operation of external warning devices). A two-second time delay occurs before light goes on and relay operates after trigger signal begins.
2. If WARN light goes on at meter percent L. E. L. reading lower or higher than desired, turn screw adjustment of ZERO potentiometer to obtain a meter reading 2 to 3 percent below the desired point.
3. Press RESET button to de-energize warning relay.

23-9617
2/28/80

3-3.1 WARNING CIRCUIT ADJUSTMENT (continued)

4. Turn screw adjustment of WARN potentiometer (R26 for CD800/830 Systems; R48, labeled W, for CD802/832 Systems) fully counter-clockwise until warning relay K1 energizes and WARN light comes on (after two-second delay past trigger point).
5. Push and hold down RESET button and turn WARN potentiometer slowly clockwise until WARN light goes off. (Time delay circuit does not operate as light goes out and relay de-energizes.)
6. Turn screw adjustment of ZERO potentiometer R24 until WARN light goes on, signifying an energized warning relay. Note per-cent L. E. L. indication at this point.
7. Repeat steps 2 through 5 for fine adjustment of warning relay trigger point.
8. Using ZERO control, rezero indicating meter after confirming that detector is sampling gas-free air.

NOTE: If adjustments do not result in setting warning reponse level at the desired percent L. E. L. meter reading, refer to TROUBLESHOOTING procedures in Section 4.

3-3.2 ALARM CIRCUIT ADJUSTMENT. Adjust alarm circuit to operate at the voltage level representing a specified percent L. E.L. gas-air mixture as follows:

NOTE: If FAIL light comes on during adjustment operations, wait 45 seconds after FAIL light goes out so that time delay circuit will not interfere with continuing adjustments.

1. To impress an alarm-level triggering signal on the alarm circuit, turn ZERO potentiometer adjustment screw slowly clockwise until alarm relay K2 energizes and ALARM light goes on (circuit card extender circuitry prevents operation of external alarm devices). A two-second time delay occurs before light goes on and relay operates after trigger signal begins.
2. If ALARM light goes on at a meter percent L. E. L. reading lower or higher than desired, turn screw adjustment of ZERO potentiometer to obtain a meter reading 2 or 3 percent below the desired point.
3. Press RESET button to de-energize alarm relay.

23-9617
7/1/76

3-3.2 ALARM CIRCUIT ADJUSTMENT (continued)

4. Turn screw adjustment of ALARM potentiometer (R29 for CD800/830 Systems; R41 labeled "A" for CD802/832 Systems) fully counter-clockwise until alarm relay energizes and ALARM light comes on (after two-second delay past trigger point).
5. Push and hold down RESET button and turn ALARM potentiometer adjustment screw slowly clockwise until ALARM light goes off. (Time delay circuit does not operate as light goes out and relay de-energizes.)
6. Turn screw adjustment of ZERO potentiometer until ALARM light goes on, signifying an energized alarm relay. Note percent L. E. L. meter reading at this point.
7. Repeat steps 2 through 5 for fine adjustment of alarm relay trigger point.

NOTE: If adjustments do not result in setting alarm response level at the desired percent L. E. L. meter reading, refer to TROUBLE-SHOOTING procedures in Section 4.

8. Return screw adjuster of ZERO potentiometer to setting that re-zeros indicating meter pointer after confirming that detector is sampling gas-free air.

3-3.3 TEST ADJUSTMENT. The TEST pushbutton, when depressed, closes a circuit to ground through one lead to differential amplifier U3, thus impressing a voltage equivalent to that which would appear on the lead if the detector were sensing a gas-air mixture of 100 percent L. E.L. Adjust test circuit to obtain a full-scale meter reading (100 percent L. E. L.) as follows:

1. Press TEST pushbutton and observe deflection of meter pointer.
2. If reading is less than full scale, or if pointer rapidly swings to a mechanical stop, turn screw adjuster of RANGE potentiometer R22 on control module printed circuit board (CD800X: located on narrow flange below opening at left inside circular window) to obtain a full-scale meter reading with TEST pushbutton depressed.
3. Observe WARN and ALARM lights. Both should go on as TEST push-button is depressed, and warning and alarm relays should energize. If not, set WARN and ALARM adjustments in accordance with paragraphs 3-3.1 and 3-3.2.

23-9617
7/1/76

3-3 ADJUSTMENTS (continued)

- 3-3.4 RECORDER OUTPUT ADJUSTMENT. At full-scale meter reading, the recorder circuit can be adjusted to provide an output of from 25 to 100 millivolts D.C., with accurate correspondence of voltage output to L. E.L. meter reading throughout the entire meter range. Adjust recorder output level as follows:
1. With external recorder (minimum input impedance 10, 000 ohms) connected to recorder terminals of control module (REC + and -), press and hold down TEST pushbutton.
 2. Observe recorder response at full-scale control module L. E. L. meter reading.
 3. Turn screw adjuster of REC potentiometer (R17 for CD800/830; R36 for CD802/832 Systems) on printed circuit board to set recorder deflection at 100 percent point on recorder graph.
 4. Release TEST pushbutton. Confirm that indicating meter and recorder return to zero.
- 3-3.5 CHECKING FAIL CIRCUITS. Fail circuits are generally tested at time of system installation, at calibration, and for maintenance and trouble-shooting. Refer to Section 4, Troubleshooting Chart 4-1D, for procedures to check fail circuits.

23-9617
5/7/80

SECTION 4MAINTENANCE AND TROUBLESHOOTING

The following maintenance program is recommended to assure that the gas alarm system is operating properly, and to detect and repair any fault that may occur for any reason. Because the manufacturer cannot anticipate or control all conditions to which an installation will be exposed during its lifetime, the user is therefore cautioned to conduct more frequent inspections and maintenance operations if experience so dictates.

4-1 DAILY INSPECTION

Daily (or as specified in operator's maintenance schedule), perform the following inspections:

Observe to determine if:

- a) Control unit is receiving power from external source.
- b) PILOT light is on.
- c) FAIL light is off.
- d) Indicating meter reads less than zero, or more than zero when no combustible gas is present at the detector.

NOTE: If meter does not read zero from causes other than presence of gas at the detector, follow zeroing procedures in paragraphs 3-2.1 or refer to Troubleshooting Chart 4-1A. Newly installed elements in the process of stabilizing response to gas condition require more frequent zero corrections. If FAIL light is on, refer to TROUBLESHOOTING CHART. A nominal 30-second delay circuit prevents alarms from responding until approximately 15 to 60 seconds after failure is cleared.

4-2 WEEKLY INSPECTION

Weekly (or as specified in operator's maintenance schedule), perform the following inspections:

1. Press and hold TEST pushbutton.

CAUTION: REMOTE ANNUNCIATION AND OTHER ACCESSORY DEVICES OPERATE FROM THE TEST PUSHBUTTON UNLESS CIRCUIT CARD EXTENDER #0023-4023 IS INSTALLED BEFORE TESTING. TO PERMANENTLY DISCONNECT REMOTE DEVICES

4-2 WEEKLY INSPECTION (continued)

FROM THE TEST PUSHBUTTON SWITCH: CUT LEADS OFF AND REMOVE JUMPER J1 FROM THE CONTROL UNIT PRINTED CIRCUIT BOARD.

2. Observe to determine if:
 - a) Meter pointer indicates full-scale readings.
 - b) WARN and ALARM light go on (after 45 seconds delay if power has been interrupted).
 - c) Recorder displays full-scale response.

3. Release TEST pushbutton and press RESET pushbutton.

4. Observe to determine if:
 - a) WARN and ALARM light go out.
 - b) Indicating meter returns to zero.
 - c) Recorder returns to zero.

5. Remove card extender, if used, and slide control assembly into connector.

NOTE: To test operation of relays: From control module terminal panel, disconnect the wires to any external devices (sprinklers, process control equipment, etc.) that should not be activated in routine testing. Connect test lamp, meter, or buzzer across relay output terminals. Press TEST pushbutton and observe response. Press RESET button at end of test and reconnect external devices.

6. Replace burned-out-panel-mounted module indicating lamps (WARN, ALARM, FAIL, and PILOT) as follows:
 - a) Grasp plastic lamp cover (pushbutton) with finger and pull to extract from panel.
 - b) CD800/830: Insert small knife blade or fingernail between end flange of lamp and end of tubular socket. Carefully pry burned out lamp from socket.
CD802/832: Extract slide based lamp from socket using long-nosed pliers, tweezers, or lamp extractor.

23-9617
7/1/76

4-2 WEEKLY INSPECTION (continued)

- c) Insert new lamp in socket and replace plastic cover (legend right-side-up) in panel.

4-3 MONTHLY MAINTENANCE

4-3.1 MONTHLY TEST AND ADJUSTMENTS. Monthly (or as specified by operator's maintenance schedule), perform the following tests and adjustments.

1. Recalibrate alarm system in accordance with procedures in Section 3, CALIBRATION AND ADJUSTMENTS.

NOTE: Alarm point settings are unaffected by recalibration.

2. If proper calibration cannot be achieved, follow Troubleshooting Chart (Figure 4-1) procedures in this section to find and correct existing problems.

NOTE: Watch for unstable conditions such as erratic percent L. E. L. readings, meter pointer drift from zero significant change in voltage across detector power leads, etc. As indications of trouble.

If sensor element is replaced, or if problems appear, include the following steps:

3. Using card extender 0023-4023 (if required) and 1-10 Volt range D. C. Voltmeter, read voltage across control-module red and black test points marked B.
4. If voltage reading across B test points does not match previously recorded reading (Paragraph 2-6. 7, step 11), turn adjustment screw of VOLT potentiometer R2 to obtain the required voltage.
5. Remove dirt, grease, and other foreign material from detector and detector housing.
6. Remove any obstructions to normal flow of air around the detector that may have accumulated between inspections.

4-3.2 FILTER SCREEN SERVICING. Monthly (or as accumulations of dust and dirt require) remove and clean floor-standing cabinet filter screens as follows:

1. Remove four screws that fasten each of two louvered front panels to cabinets. Remove front panels and filter screens from cabinet.

23-9617
7/1/76

4-3 MONTHLY MAINTENANCE (continued)

4-3.2 Filter Screening Servicing (continued)

2. Flush filter screens with clean water, using fine-spray hose or immersion. (Soap and water may be used.)
3. Dry filter screens. Heat or compressed air may be used to facilitate drying.
4. Install screens and louvered front panels on cabinet.

4-4 SPECIAL MAINTENANCE PROBLEMS

4-4.1 PAINTING. When painting the detector housing or vicinity, cover or other-wise protect the flame arrestor cover of the sensor element from paint overspray.

4-4.2 DETECTOR IMMERSION. If the detector is accidentally immersed in clean water, operate in gas-free air for 5 or 6 hours until detector is completely dry; then calibrate and adjust in accordance with procedures in Section 3, CALIBRATION AND ADJUSTMENTS. Discard and replace sensor element if response is marginal or inadequate. If detector is immersed in water contaminated with dirt, solvent, or other combustible materials, discard and replace sensor element. Do not attempt to restore or use the element further.

4-5 TROUBLESHOOTING.

Highest quality components assure that CD800/830 and CD802/832 systems will be as troublefree as the state of the art permits. If difficulties beyond routine maintenance and adjustment occur, troubleshoot in accordance with the following paragraphs.

4-5.1 GENERAL PREPARATIONS FOR TROUBLESHOOTING:

1. Check for loose or broken wires.
2. Turn power off and observe position of indicating meter pointer. Turn mechanical screw adjustment under meter to adjust pointer to zero reading if necessary.
3. Make certain that detector is in pure, gas-free air (using J-W combustible gas indicator and J-W gas calibration kit with 100% nitrogen or zero-gas, dry-air cylinder if necessary, in accordance with paragraph 3-2.1, step 3, instruction).

23-9617
7/1/76

4-5 TROUBLESHOOTING (continued)

4-5.1 General Preparations For Troubleshooting. (continued)

4. With power on, adjust detector operating voltage in accordance with instructions in paragraph 2-6. 7.

4-5.2 TROUBLESHOOTING CHARTS. Troubleshooting charts (Figure 4-1) outline steps to detect and remedy faulty conditions that cause meter to read off zero under fresh air conditions, warn and alarm circuit failure, more-or-less-than-full-scale meter pointer deflection in response to 100% L. E. L. signals, fail circuitry malfunction, and faulty module response to gas conditions at the detector. Troubleshooting procedures follow the order in which one circuit is dependent upon the others; therefore deviations from the steps outlined in the charts are likely to result in inefficient and ineffective troubleshooting.

23-9617
7/1/76

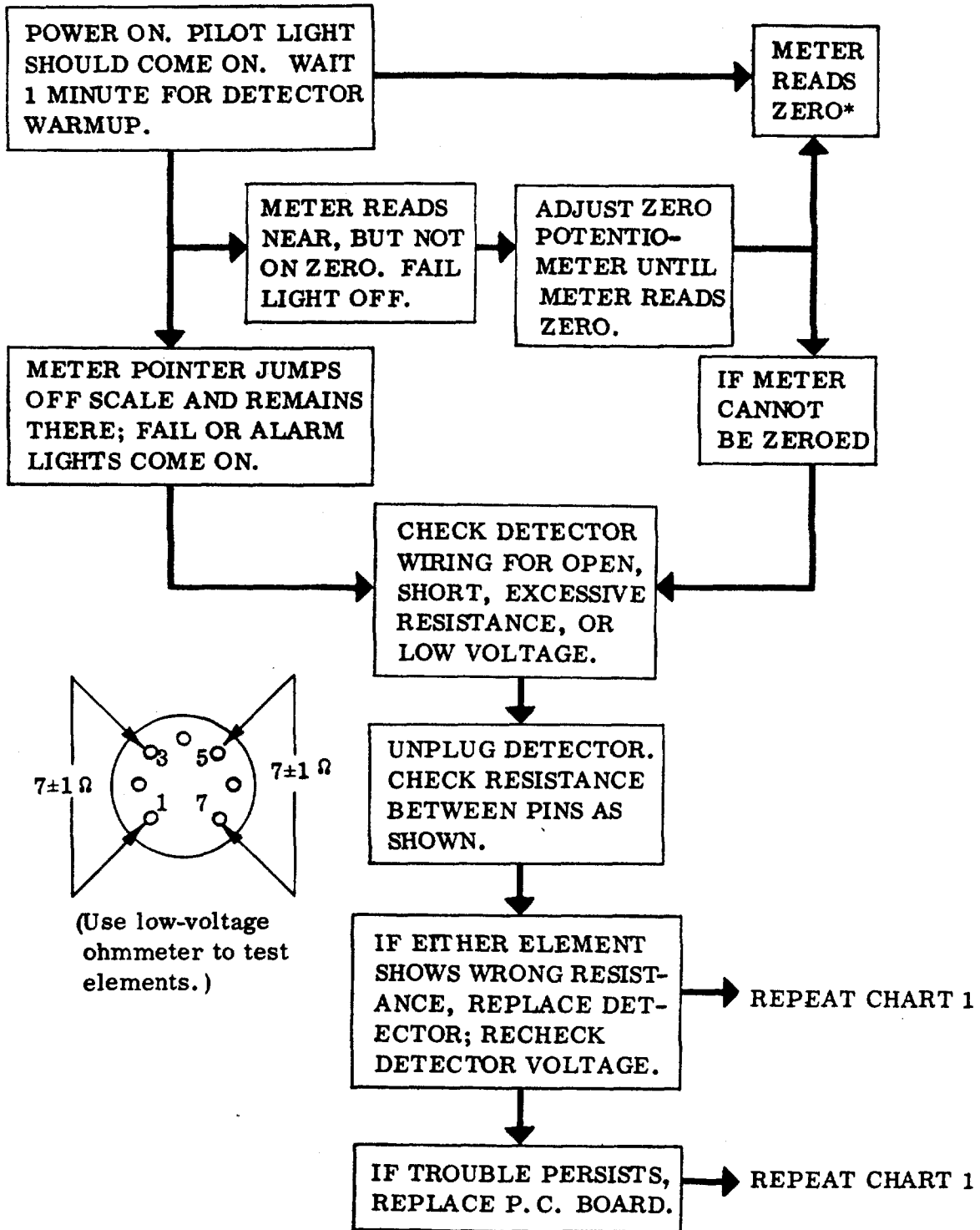

Figure 4-1A. Troubleshooting Chart 1: Zeroing Meter Pointer

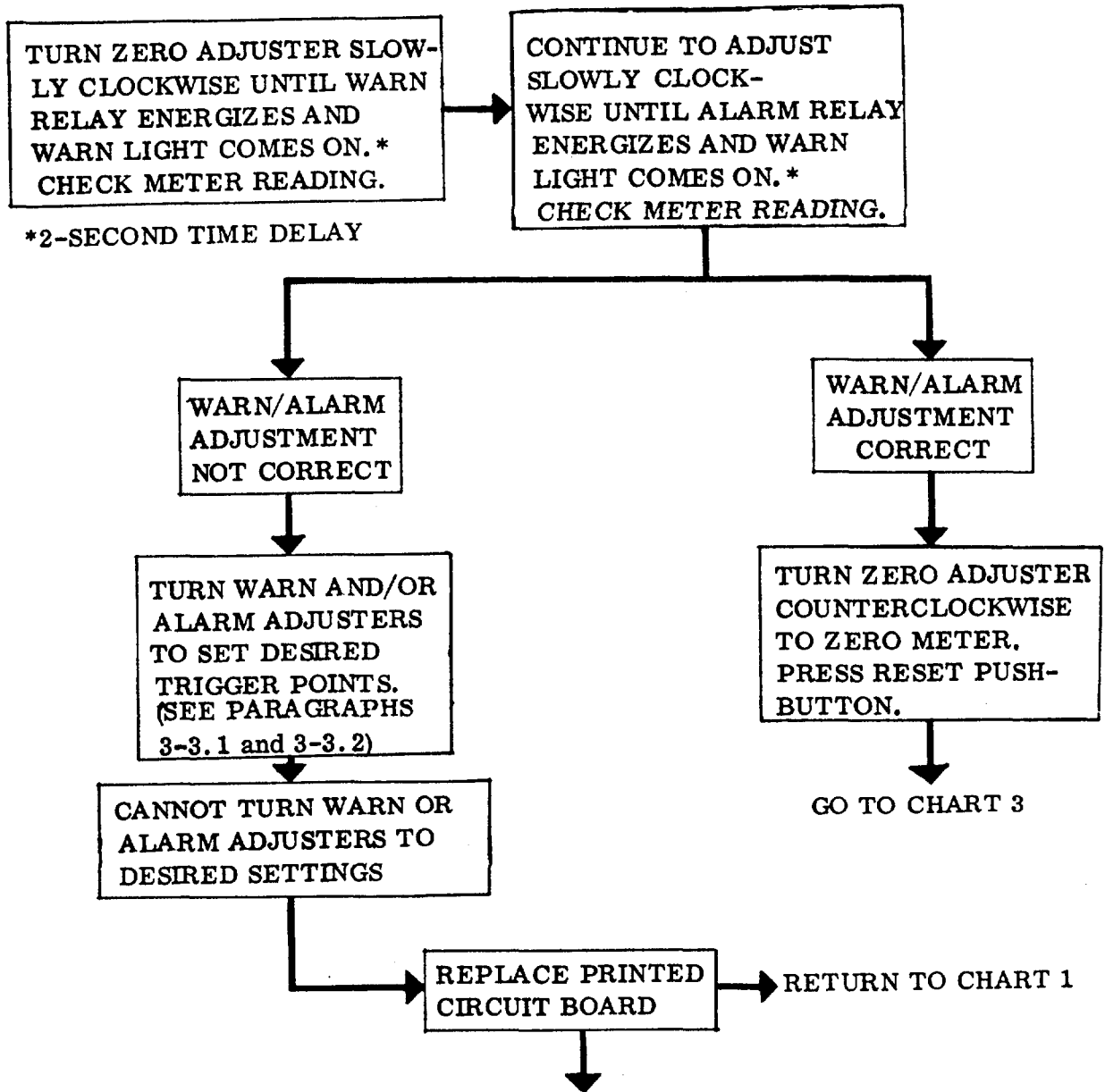

Figure 4-1B. Troubleshooting Chart 2: Adjusting Warn and Alarm Response Levels

23-9617
7/2/79

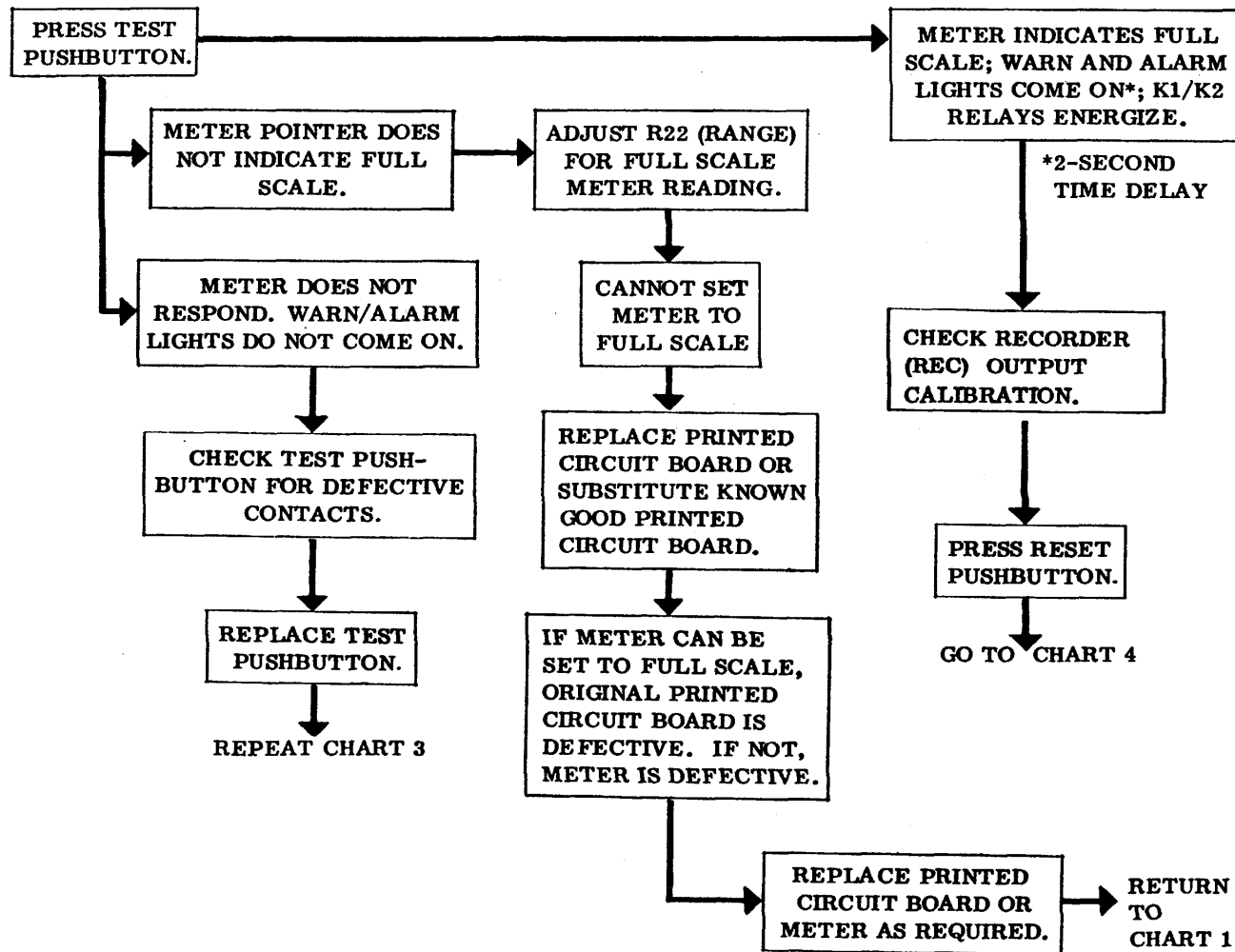

Figure 4-1C. Troubleshooting Chart 3: Adjusting for Full-Scale Deflection of Meter Pointer

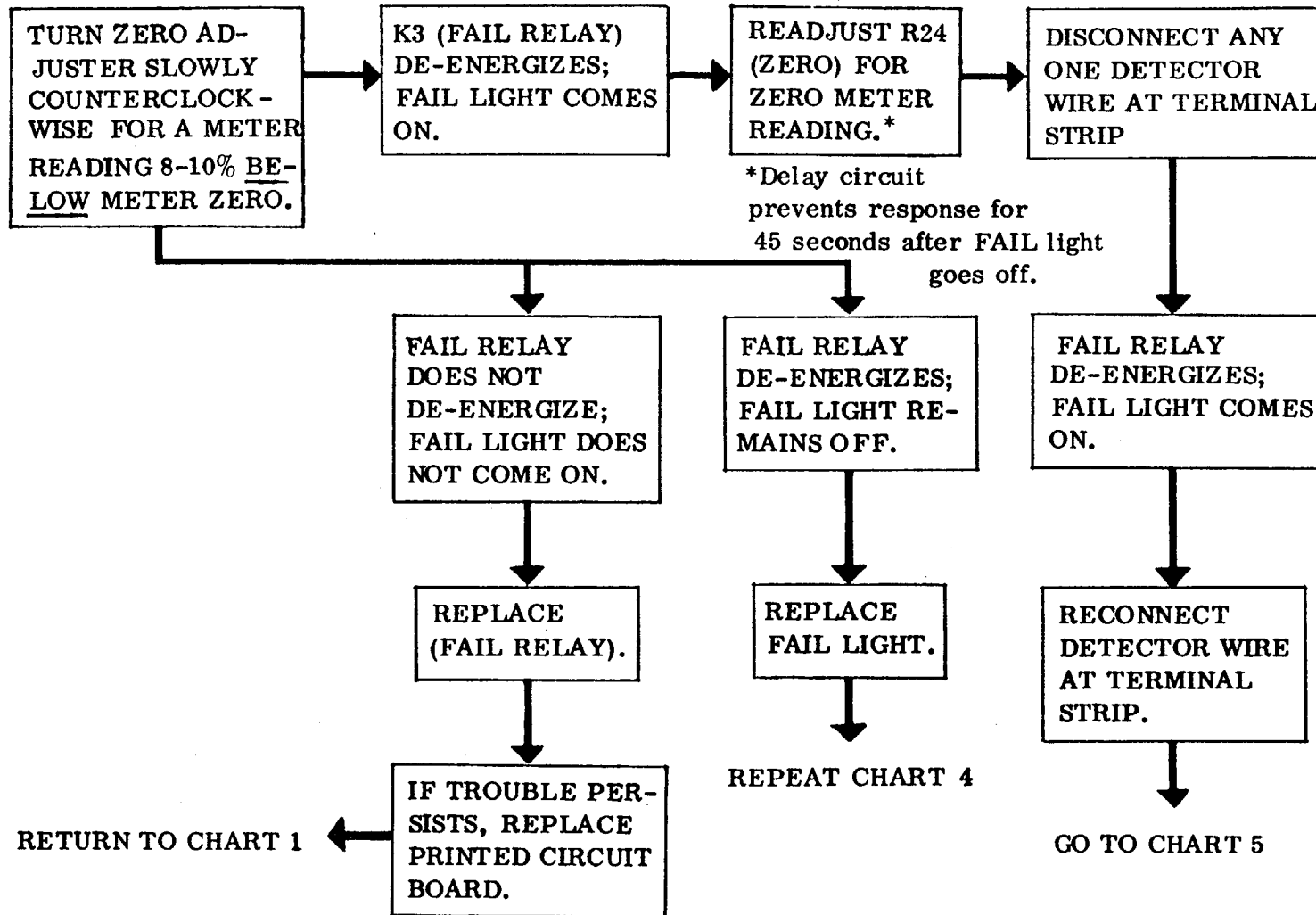

Figure 4-1D. Troubleshooting Chart 4. Fail Circuit Testing and Repairs

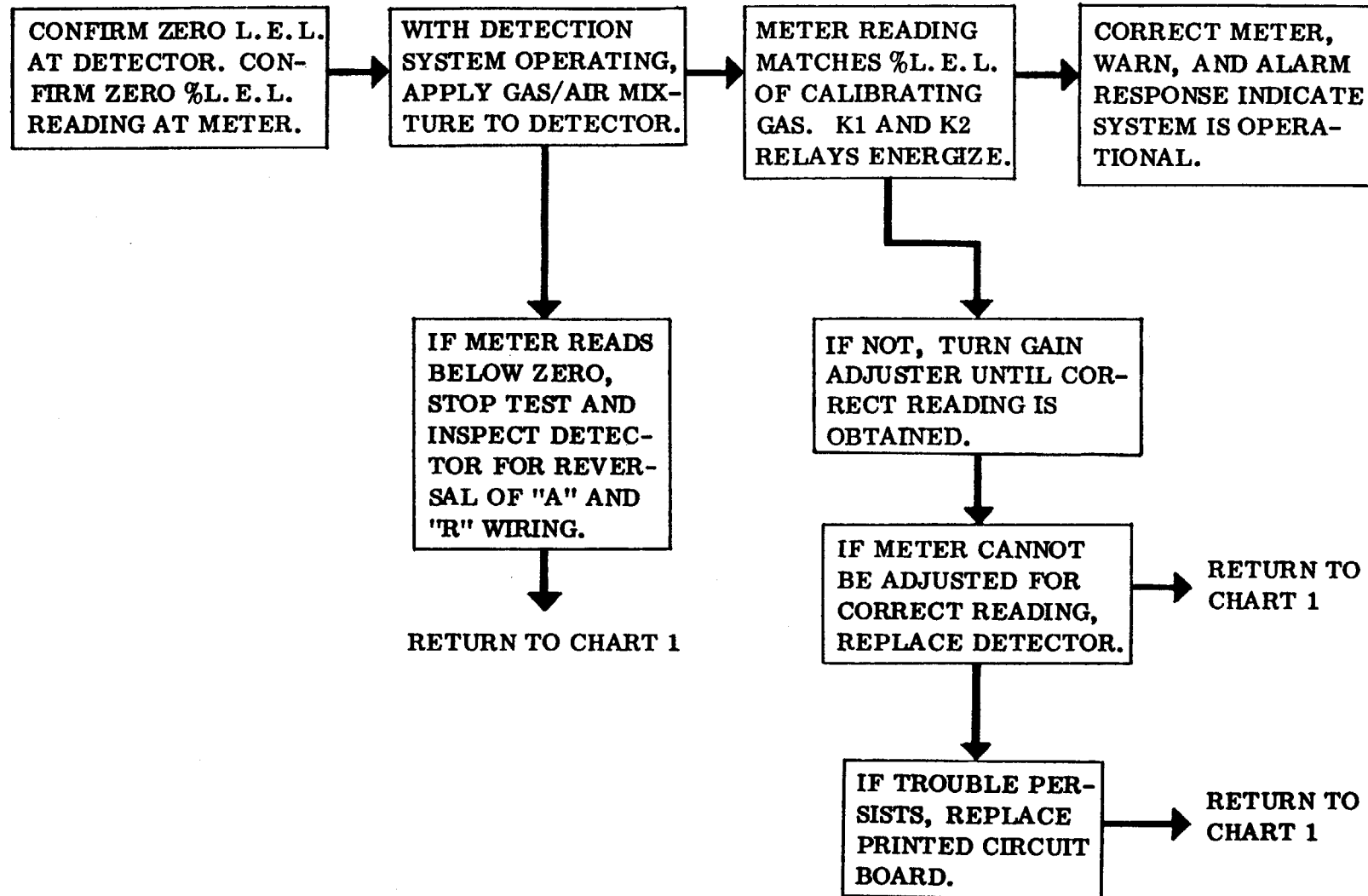

Figure 4-1E. Troubleshooting Chart 5: Calibrating Meter Response to Gas Concentration Levels

23-9617
7/1/76

(Part incorporated in instrument systems designated by X)

SECTION 5

PARTS LIST

<u>ITEM</u>	<u>PART NO.</u>	CD800W	CD802W	CD800X	CD802X	CD830 Instrument in CD800P Enclosure	CD830 Instrument in CD800PF Enclosure	CD832 Instrument in CD800P Enclosure	CD832 Instrument in CD800PF Enclosure	CD830 Instrument in CD830R6 Rack Adapter	CD832 Instrument in CD830R6 Rack Adapter	CD830 Instrument in CD830P6 Panel	CD832 Instrument in CD830P6 Panel	CD830 Instrument in CD830W4/8 Cabinet	CD832 Instrument in CD830W4/8 Cabinet	CD830 Instrument in CD830F36 Cabinet	CD832 Instrument in CD830F36 Cabinet
CD800W Wall Cabinet with one single-channel control unit, top hub:																	
with standard relays:	23-7179	X*															
with sealed relays:	23-7180	X*															
CD800W Wall Cabinet with one single-channel control unit, bottom hub:																	
with standard relays:	23-7181	X*															
with sealed relays:	23-7186	X*															
CD802W Wall Cabinet with one dual-channel control unit, top hub:																	
with standard relays:	51-7011		X*														
with sealed relays:	51-7012		X*														
CD802W Wall Cabinet with one dual-channel control unit, bottom hub:																	
with standard relays:	51-7013		X*														
with sealed relays:	51-7014		X*														
CD800X Explosion-proof Wall-mounting Enclosure with single-channel control unit	23-7178			X													
CD802X Explosion-proof, Wall-mounting Enclosure with dual-channel control unit					X												

(* = option: Select one from sets of alternatives between horizontal lines.)

(Part incorporated in instrument systems designated by X)

SECTION 5

PARTS LIST (continued)

<u>ITEM</u>	<u>PART NO.</u>	CD800W	CD802W	CD800X	CD802X	CD830 Instrument in CD800P Enclosure	CD830 Instrument in CD800PF Enclosure	CD832 Instrument in CD800P Enclosure	CD832 Instrument in CD800PF Enclosure	CD830 Instrument in CD830R6 Rack Adapter	CD832 Instrument in CD830R6 Rack Adapter	CD830 Instrument in CD830P6 Panel	CD832 Instrument in CD830P6 Panel	CD830 Instrument in CD830W4/8 Cabinet	CD832 Instrument in CD830W4/8 Cabinet	CD830 Instrument in CD830 F36 Cabinet	CD832 Instrument in CD830 F36 Cabinet
CD800P Enclosure (requiring extender card)	23-7318					X		X									
Extender Card	23-4023			X	X			X									
CD800PF Enclosure with flexible cable	23-7319						X		X								
CD830W4 Wall-mounting Cabinet with conduit entries	23-7175													X	X		
CD830W8 Wall-mounting Cabinet with conduit entries	23-7176													X	X		
CD830R6 19-inch Rack Adapter for six control modules	506-086-10									X	X	X	X			X	X
CD830P6 Front Panel and 19-inch Rack Adapter	506-086-20											X	X				
CD830 F Floor-standing Cabinet for up to 36 control modules	506-201-00															X	X
Panel Ass'y, Module Replacem't	23-7177									X	X	X	X	X	X	X	X
CD830 Single-channel Control Module:																	
with standard relays:	51-7040					X*	X*			X*		X*		X*		X*	
with sealed relays:	51-7041					X*	X*			X*		X*		X*		X*	
without relays:	51-0179					X*	X*			X*		X*		X*		X*	
(* = option: Select one from sets of alternatives between horizontal lines.)																	

(Part incorporated in instrument systems designated by X)

SECTION 5

PARTS LIST (continued)

<u>ITEM</u>	<u>PART NO.</u>	CD800W	CD802W	CD800X	CD802X	CD830 Instrument in CD800P Enclosure	CD830 Instrument in CD800PF Enclosure	CD832 Instrument in CD800P Enclosure	CD832 Instrument in CD800PF Enclosure	CD830 Instrument in CD830R6 Rack Adapter	CD832 Instrument in CD830R6 Rack Adapter	CD830 Instrument in CD830P6 Panel	CD832 Instrument in CD830P6 Panel	CD830 Instrument in CD830W4/8 Cabinet	CD832 Instrument in CD830W4/8 Cabinet	CD830 Instrument in CD830F36 Cabinet	CD832 Instrument in CD830F36 Cabinet
CD832 Dual-channel Control Module: with standard relays: with sealed relays: without relays:	51-7020							X*	X*		X*		X*		X*		X*
	51-7021							X*	X*		X*		X*		X*		X*
	23-5029							X*	X*		X*		X*		X*		X*
Relay, Standard	0004-5191	X*	X*	X*	X*	X*	X*	X*	X*	X*	X*	X*	X*	X*	X*	X*	X*
Relay, Sealed	361-071-00	X*	X*	X*	X*	X*	X*	X*	X*	X*	X*	X*	X*	X*	X*	X*	X*
Spring, Relay Hold-down	0104-7702	X	X	X		X	X	X	X	X	X	X	X	X	X	X	X
Printed Circuit Board, CD800/CD830 control units (less relays)	23-4043	X		X		X	X	X		X		X		X		X	
Printed Circuit Board, CD802/832 control units (less relays)	23-5021		X		X			X	X		X		X		X		X
CD800W Front Panel Assembly	23-4769	X															
CD802W Front Panel Assembly	23-5027		X														
Meter Assembly: Jewell Type 81T, 1 mA, 0-100% L.E.L. scale	23-4101		X	X	X	X	X	X	X	X	X	X	X	X	X	X	X
General Electric DW91, 1 mA, 0-100% L.E.L. scale	23-4052	X															

(* = option: Select one from sets of alternatives between horizontal lines.)

(Part incorporated in instrument systems designated by X)

SECTION 5

PARTS LIST (continued)

<u>ITEM</u>	<u>PART NO.</u>	CD800W	CD802W	CD800X	CD802X	CD830 Instrument in CD800P Enclosure	CD830 Instrument in CD800PF Enclosure	CD832 Instrument in CD800P Enclosure	CD832 Instrument in CD800PF Enclosure	CD830 Instrument in CD830R6 Rack Adapter	CD832 Instrument in CD830R6 Rack Adapter	CD830 Instrument in CD830P6 Panel	CD832 Instrument in CD830P6 Panel	CD830 Instrument in CD830W4/S Cabinet	CD832 Instrument in CD830W4/S Cabinet	CD830 Instrument in CD830F36 Cabinet	CD832 Instrument in CD830F36 Cabinet
Lenses:																	
Green (Pilot)	23-4018	X		X	X												
Red (Alarm)	353-201-10	X		X													
Red (Alarm)	0104-6826		X														
Amber (Warn/Test)	353-203-10	X				X	X	X	X	X	X	X	X	X	X	X	X
Amber (Test)	23-5062		X														
Blue (Fail)	353-204-10	X		X													
Blue (Fail)	23-5061		X			X	X	X	X	X	X	X	X	X	X	X	X
Red (Reset)	23-5063					X	X	X	X	X	X	X	X	X	X	X	X
Red	0104-6826																
Switches:																	
Pushbutton	355-052-00	X															
Rotary	0104-0218		X		X			X	X		X		X		X		X
Pushbutton (Test, Reset)	0104-0614		X			X	X	X	X	X	X	X	X	X	X	X	X
Test	355-018-00			X													
Reset	355-016-00			X													
Bushings, Switch, Explosion-proof																	
Bushing	352-732-00			X													
Zero Adjust Ass'y with Bushing	23-4408			X	X												
Potentiometer, Test Range Adjust																	
Potentiometer	0004-4963			X	X												
Indicator (Fail)																	
Indicator	0004-9722		X		X	X	X	X	X	X	X	X	X	X	X	X	X
Lamp, 12V																	
Lamp	354-059					X	X	X	X	X	X	X	X	X	X	X	X
Light-emitting Diode (LED), Green (channel indicator, power-on indicator)																	
LED	0204-2445		X		X	X	X	X	X	X	X	X	X	X	X	X	X
Light-emitting Diode (LED), Red (Alarm, Warn channel indicator)																	
LED	0204-2446		X		X			X	X		X		X		X		X

23-9617 3/28/78

(Part incorporated in instrument systems designated by X)

SECTION 5

PARTS LIST (continued)

23-9617
(4/4/78)

ITEM	PART NO.	(Part incorporated in instrument systems designated by X)															
		CD800W	CD802W	CD800X	CD802X	CD830 Instrument in CD800P Enclosure	CD830 Instrument in CD800PF Enclosure	CD832 Instrument in CD800P Enclosure	CD832 Instrument in CD800PF Enclosure	CD830 Instrument in CD830R6 Rack Adapter	CD832 Instrument in CD830R6 Rack Adapter	CD830 Instrument in CD830P6 Panel	CD832 Instrument in CD830P6 Panel	CD830 Instrument in CD830W4/8 Cabinet	CD832 Instrument in CD830W4/8 Cabinet	CD830 Instrument in CD830 F36 Cabinet	CD832 Instrument in CD830 F36 Cabinet
Fuse, 115/230 VAC(3AG 1/2A)	355-731			X	X												
Fuse, 12 VDC(3AG 2A)	04-2624			X	X												
Fuse, 115/230 VAC(3AG 1A-S.B.)	04-2655								X	X							
Fuse, 12 VDC(3AG 10A)	355-719								X	X							
Fuse "F1"(3AG 2ASB)	355-741												X				
Fuse "F2"(3AG 4A)	355-715												X [⊖]	X [⊖]			
Fuse "F2"(3AG 8A)	355-722												X [⊕]	X [⊕]			
Fuseholder	355-796-00																
Detector Assembly, Diffusion-type, Explosion-proof, Weather-proof (less sensing element)	23-4012			*Optional	-	all systems											
Detector Assembly, Diffusion-type, Explosion-proof, Duct-mounting (less sensing element)	23-4014			*Optional	-	all systems											
Detector Assembly, Sample-drawing, Explosion-proof (less sensing element)	23-4017			*Optional	-	all systems											
Detector Assembly, Diffusion-type, Explosion-proof, Weather-proof (less sensing element)	800-086.00			*Optional	-	all systems											
Detector Assembly, Diffusion-type, Explosion-proof, Weather-proof, with high-humidity shield (less sensing element)	23-7317			*Optional	-	all systems											
		(* = option: Select one from sets of alternatives between horizontal lines.)															

(Part incorporated in instrument systems designated by X)

SECTION 5

PARTS LIST (continued)

<u>ITEM</u>	<u>PART NO.</u>	CD800W	CD802W	CD800X	CD802X	CD830 Instrument in CD800P Enclosure	CD830 Instrument in CD800PF Enclosure	CD832 Instrument in CD800P Enclosure	CD832 Instrument in CD800PF Enclosure	CD830 Instrument in CD830R6 Rack Adapter	CD832 Instrument in CD830R6 Rack Adapter	CD830 Instrument in CD830P6 Panel	CD832 Instrument in CD830P6 Panel	CD830 Instrument in CD830W4/8 Cabinet	CD832 Instrument in CD830W4/8 Cabinet	CD830 Instrument in CD830F36 Cabinet	CD832 Instrument in CD830F36 Cabinet	
Detector Elements:																		
Methane and natural gas	800-080.10	}				}	}	}	}	}	}	}	}	}	}	}	}	}
Gasoline, L.P. Gas (propane, etc)	800-080.20																	
Hydrogen	800-080.40																	
Olefins (ethylene, ethylene oxide)	800-080.50																	
Carbon monoxide	800-080.70																	
(See selection guide table following Parts List)																		
ACCESSORIES:																		
Extender Card	23-4023				X	X		X		X	X	X	X	X	X	X	X	X
Test Socket Adapter	23-4027	X	X	X	X	X	X	X	X	X	X	X	X	X	X	X	X	X
Calibration Test Kit	23-7260	X	X	X	X	X	X	X	X	X	X	X	X	X	X	X	X	X
Test Cup (for 800-086.00, 23-7317, and 23-4014 detectors)	347-095.00	Applicable all systems using 800-086, 23-7317, or 23-4014 detectors																
Test Cup (for 23-4012 detector)	23-4098	Applicable all systems using 23-4012 detectors																
Calibration Gas Cylinder(s):																		
100% Nitrogen	23-4003	}				}	}	}	}	}	}	}	}	}	}	}	}	}
Zero-gas/dry-air	23-4004																	
2% Hydrogen in air	23-4005																	
1% Methane in air	23-4006																	
2% Methane in air	23-4007																	
3% Methane in air	23-4008																	
1% Propane in air	23-4009																	
Applicable all systems, depending on gas to be detected																		

23-9617 7/22/77

(Part incorporated in instrument systems designated by X)

SECTION 5

PARTS LIST (continued)

<u>ITEM</u>	<u>PART NO.</u>	CD800W	CD802W	CD800X	CD802X	CD830 Instrument in CD800P Enclosure	CD830 Instrument in CD800PF Enclosure	CD832 Instrument in CD800P Enclosure	CD832 Instrument in CD800PF Enclosure	CD830 Instrument in CD830R6 Rack Adapter	CD832 Instrument in CD830R6 Rack Adapter	CD830 Instrument in CD830P6 Panel	CD832 Instrument in CD830P6 Panel	CD830 Instrument in CD830W4/8 Cabinet	CD832 Instrument in CD830W4/8 Cabinet	CD830 Instrument in CD830F36 Cabinet	CD832 Instrument in CD830F36 Cabinet
Calibration Gas Cylinder(s) (continued):																	
1.5% Vinyl Chloride in air	23-4010																
1% Ethylene in air	23-4011																
2.5% Natural Gas in air	23-1296																
2.2% Methane in air	23-1473																
Professional Calibration Kit	51-7070																

Applicable all systems

Applicable all systems

NOTE: CD830 control module front-panel parts listings follow documentation for 1977 models. 1977-model parts and corresponding pre-1977-model parts for CD830 module front panel are listed in Table 5-2, and illustrated in Figure 5-1.

23-9617
4/14/77

Table 5-2. Post-1977/pre-1977 Models: CD830 Control Module Front Panel Parts List Comparison (See Figure 5-1.)

<u>ITEM</u>	<u>POST-1977 MODEL</u>	<u>PRE-1977 MODEL</u>
Front Panel Subassembly	23-5040	341-180-00
Handle	23-5030	340-930
Lenses:		
Amber (TEST)	None	353-203-10
Yellow (TEST)	23-5062	None
Green (PILOT/ON-OFF)	None	353-202-10
Blue (FAIL)	23-5061	353-204-10
Red (ALARM/RESET)	None	353-201-20
Red (RESET)	23-5063	None
LED (Light-emitting diode) green power-on indicator	0204-2445	None
Socket, Fail Indicator Light (Indicator base)	0004-9722	353-416-00
Lamp, 12V	0004-3608	354-059-00
Switches:		
Pushbutton (TEST)	0104-0614	355-052
Pushbutton (RESET)	0104-0614	355-052
Pushbutton (PILOT-ON/OFF)	None	355-051-00
Meter Assembly, % L. E. L.	23-4101	23-4101
Control Module Assembly		
With standard relays	51-7040	23-7187
With sealed relays	51-7041	23-7189
Without relays	51-0179	23-7188

23-9617
11/8/79

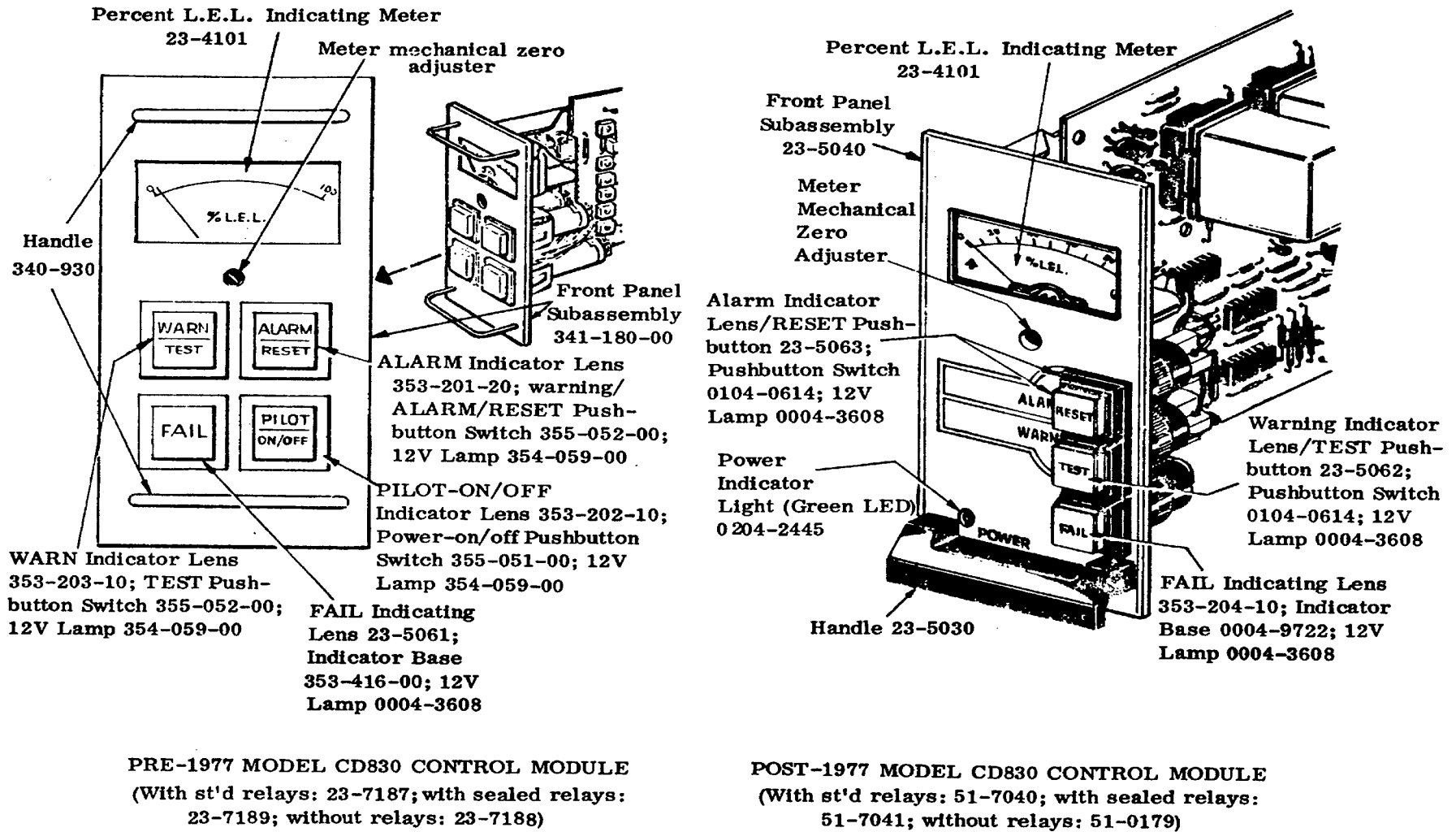

Figure 5-1. Pre-1977/post 1977 Models: CD830 Control Module Front Panel Parts Comparison

Table 5-1. Detector Element Selection Guide

SELECTION GUIDE

RATING KEY:

A=CORRECT CHOICE

B=WILL PERFORM WELL, BUT "A" CHOICE IS MORE ECONOMICAL

C=WILL OPERATE BUT WITH DEGRADED PERFORMANCE

D= NOT SUITABLE

BLANK=NO EVALUATION HAS BEEN ATTEMPTED

LEAST EXPENSIVE 800-080.2
 ↑
 800-080.1
 ↓
 MOST EXPENSIVE 800-080.4
 800-080.5

NOTE:

All catalytic-type detectors are inherently susceptible to a loss of sensitivity if exposed to silicone compounds. Special J-W design and manufacturing techniques provide substantial resistance to silicone "poisoning"; nevertheless, where rapid loss in detector sensitivity is noted, the presence of abnormally high concentrations of silicone should be considered as a possible cause.

GASES	800-080.1	800-080.2	800-080.4	800-080.5	GASES	800-080.1	800-080.2	800-080.4	800-080.5
	ACETONE	D	D	C		A	I.P.A. (ISOPROPYL ALCOHOL)	C	A
ALCOHOL-ETHYL, BUTYL	C	A	D	D	ISOPROPYLAMINE	D	A	B	B
ALCOHOL-METHYL	C	A	B	B	J. P. 4. (JET FUEL)	C	A	B	B
AMMONIA	C	A	C	C	KEROSENE	C	A	B	B
ACETYLENE	D	D	C	A	KETONES	D	D	C	A
ACRYLONITRILE	D	D	C	A	METHANE	A	D	C	B
ARGON	D	D	D	D	METHYL CYCLOHEXANE	D	A	B	B
BENZOL	D	D	C	A	METHYL ACRYLATE	C	A	C	C
BUTADIENE	D	D	D	A	METHYL CHLORIDE	C	D	C	A
BUTANE	C	A	B	B	M. E. K.	D	D	C	A
CYCLO HEXANE	D	D	D	A	METHYL ISOBUTYL KETONE	D	D	B	A
CARBON DISULFIDE	D	D	D	A	METHYL METHACRYLATE	C	A	B	B
CARBON MONOXIDE	D	D	A	C	METHYLENE CHLORIDE	C	D	C	A
CHLOROBENZENE	C	C	A	D	NAPHTHA	C	A	B	B
CHLOROFORM	C	C	C	A	NATURAL GAS	A	C	B	B
CARBON TETRACHLORIDE	D	D	D	D	N-OCTANE	C	A	B	B
DIETHYLAMINE	D	A	B	B	N-PENTANE	C	A	B	B
DICHLOROPROPANE	C	D	C	A	PROPANE	C	A	B	B
DICHLOROETHANE	C	D	D	A	PROPYLENE	D	D	C	A
ETHANE	A	C	B	C	PROPYLENE OXIDE	D	D	C	A
ETHYL ACETATE	C	A	B	C	PHENOL	C	C	A	B
ETHYL ACRYLATE	C	A	B	B	STYRENE	D	D	C	A
ETHYL CELLOSOLVE	C	C	A	B	TOLUENE	D	D	C	A
ETHYL CHLOROACETATE	C	C	C	A	TRIETHYLAMINE	D	A	B	B
ETHYLENE	D	D	C	A	TRICHLOROETHANE	C	D	C	A
ETHYLENE OXIDE	D	D	D	A	TURPENTINE	C	C	C	A
ETHYL ETHER	D	D	C	A	VINYL ACETATE	C	C	C	A
FORMALDEHYDE	C	C	C	A	VINYL CHLORIDE	C	D	C	A
GASOLINE	C	A	B	B	XYLENE	D	D	C	A
HEPTANE	C	A	B	B					
HEXANE	C	A	B	B					
HYDROGEN	C	C	A	B					
H2S	C	C	A	B					

APPENDIX A

REFERENCES

A-1. **Scope.** This appendix contains all forms, pamphlets and technical manuals referenced in both the Air mobile and Semitrailer mounted Laboratories.

A-2. **Forms.**

Recommended changes to Publications	DA Form 2028 DA Form 2028-2
Quality Deficiency Report	SF 368
Equipment Inspection and Maintenance Work Sheet	DA Form 2404
Hand Receipts	DA Form 2062

A-3. **Field Manuals.**

Petroleum Testing Facilities: Laboratories and Kits	FM 10-72
Inspecting and Testing Petroleum Products	FM 10-70
ASTM Test Method Supplement to	FM 10-92C1/C2

A-4. **Technical Manuals.**

Atlas-Copco Compressor	TM 10-4310-392-13&P
Alcor Jet Fuel Thermal Oxidation Tester Operating and Maintenance Manual	TM 10-6635-210-13&P
Bacharach Gas Alarm and Calibration Data	TM 10-6665-297-13&P
Brother Portable Typewriter	TM 10-7430-218-13&P
Chemtrix Field Ph Meter	TM 10-6630-237-13&P
Elkay Manufacturing 30 GPH Cooler	TM 10-4130-240-13&P
Emcee Micro-Separometer	TM 10-6640-222-13&P
Foxboro Pressure Recording Gauge	TM 10-6685-365-13&P
Gammon Aqua Glo Water Detector	TM 10-6640-221-13&P
Gammon Mini Monitor Fuel Sampling Kit	TM 10-6630-230-13&P
Jelrus Burn-Out Furnace	TM 10-6640-231-13&P
Koehler Cleveland Open Tester	TM 10-6630-236-13&P
Koehler Cloud and Pour Point Chamber	TM 10-6630-238-13&P
Koehler Copper Strip Corrosion Bomb Bath	TM 10-6640-220-13&P
Koehler Distillation Apparatus	TM 10-6630-233-13&P
Koehler Dropping Point Apparatus	TM 10-6635-211-13&P
Koehler Electric Pensky-Martins Tester	TM 10-6630-231-13&P
Koehler Foaming Characteristics Determination Apparatus	TM 10-6640-228-13&P
Koehler Kinematic Viscosity Bath	TM 10-6630-239-13&P
Koehler Tag Closed Cup Flash Tester	TM 10-6630-235-13&P
Lab-Line Explosion Proof Refrigerator	TM 10-6640-219-13&P
Lily Freezer	TM 10-6640-234-13&P
Millipore OM 39 Filter Holder	TM 10-6640-225-13&P
Millipore Vacuum Pump	TM 10-6640-217-13&P
Ohaus Harvard Trip Balance	TM 10-6670-278-13&P
Precision Gas-Oil Distillation Test Equipment	TM 10-6630-219-13&P
Precision General Purpose Water Bath	TM 10-6640-229-13&P

Precision High Temperature Bronze Block Gum Bath	TM 10-6630-234-13&P
Precision General Purpose Ovens	TM 10-6640-218-13&P
Precision Heater Instruction Manual and Parts List	TM 10-6640-223-13&P
Precision Oxidation Stability Bath	TM 10-6640-232-13&P
Precision Pensky-Martens Flash Testers	TM 10-6630-231-13&P
Precision Reid Vapor Pressure Bath	TM 10-6640-226-13&P
Precision Slo-Speed Stirrer	TM 10-6640-224-13&P
Precision Universal Centrifuge	TM 10-6640-230-13&P
Precision Universal Penetrometer.....	TM 10-6640-228-13&P
Sargent-Welch Vacuum Pump.....	TM 10-4310-391-13&P
Sartorius Analytical Balance	TM 10-6670-277-13&P
Scotsman Cuber.....	TM 10-6640-227-13&P
Soltec VOM-Multimeter	TM 10-6625-3127-13&P
Teel Self-Priming Centrifugal Pump	TM 10-6640-217-13&P
Teel Submersible Pump	TM 10-4320-320-13&P
Texas Instrument TI-5030II Calculator	TM 10-7420-210-13&P

A-5. Pamphlets.

The Army Maintenance Management System (TAMMS).....	DA Pam 738-750
---	----------------

A-6. Miscellaneous Publications.

The Army Integrated Publishing and Printing Program.....	AR 25-30
Laboratory, Airmobile, Aviation Fuel	MIL-L-52733A(ME)
Apparatus, Instruments, Chemicals, Furniture, and Supplies for Industrial, Clinical, College and Government Laboratories	Fisher Scientific Laboratories Catalog
Petroleum-Petrochemical Testing Equipment	Precision Scientific Catalog

APPENDIX B

MAINTENANCE ALLOCATION CHART

SECTION I. INTRODUCTION

B-1. **General.**

a. This section provides a general explanation of all maintenance and repair functions authorized at various maintenance categories.

b. The Maintenance Allocation Chart (MAC) in Section II designates overall authority and responsibility for the performance of maintenance functions on the identified end item or component. The application of the maintenance functions to the end item or component will be consistent with the capacities and capabilities of the designated maintenance categories.

c. Section II lists the tools and test equipment (both special tools and common tool sets) required for each maintenance function as referenced from Section II.

d. Section IV contains supplemental instructions and explanatory notes for a particular maintenance function.

B-2 **Maintenance Functions.** Maintenance functions will be limited to and defined as follows:

a. Inspect. To determine the serviceability of an item by comparing its physical, mechanical, and/or electrical characteristics with established standards through examination (e.g., by sight, sound, or feel).

b. Test. To verify serviceability by measuring the mechanical, pneumatic, hydraulic, or electrical characteristics of an item and comparing those characteristics with prescribed standards.

c. Service. Operations required periodically to keep an item in proper operating condition, i.e., to clean (includes decontaminate, when required), to preserve, to drain, to paint, or to replenish fuel, lubricant⁵, chemical fluids, or gases.

d. Adjust. To maintain or regulate, within prescribed limits, by bringing into proper or exact position, or by setting the operating characteristics to specified parameters.

e. Align. To adjust specified variable elements of an item to bring about optimum or desired performance.

f. Calibrate. To determine and cause corrections to be made or to be adjusted on instruments or test, measuring, and diagnostic equipments used in precision measurement. Consists of comparisons of two instruments, one of which is a certified standard of knob accuracy, to detect and adjust any discrepancy in the accuracy of the instrument being compared.

g. Remove/Install. To remove and install the same item when required to perform service or other maintenance functions. Install may be the act of emplacing, seating, or fixing into position a spare, repair part, or module (component or assembly) in a manner to allow the proper functioning of an equipment or system.

h. Replace. To remove an unserviceable item and install a serviceable counterpart in its place. "Replace" is authorized by the MAC and is shown as the third position code of the SMR code.

i. Repair. The application of maintenance services, including fault location/troubleshooting,² removal/installation, and disassembly/assembly procedures³ and maintenance actions, to identify troubles and restore serviceability to an item by correcting specific damage, fault, malfunction, or failure in a part, subassembly, module (component or assembly), end item, or system.

j. Overhaul. That maintenance effort (service/action) prescribed to restore an item to a completely serviceable/operational condition as required by maintenance standards in appropriate technical publications (i.e., DMWR). Overhaul is normally the highest degree of maintenance performed by the Army. Overhaul does not normally return an item to like-new condition.

k. Rebuild. Consists of those services/actions necessary for the restoration of unserviceable equipment to a like-new condition in accordance with original manufacturing standards. Rebuild is the highest degree of materiel maintenance applied to Army equipment. The rebuild operation includes the act of returning to zero those age measurements (hours/miles, etc.) considered in classifying Army equipment/components.

B-3. Explanation Of Columns In The MAC, Section II.

a. Column 1. Group Number. Column 1 lists functional group code numbers, the purpose of which is to identify maintenance significant components, assemblies, subassemblies, and modules with the next higher assembly. End item group number shall be "00."

b. Column 2. Component/Assembly. Column 2 contains the names of components, assemblies, subassemblies, and modules for which maintenance is authorized.

c. Column 3. Maintenance Function. Column 3 lists the functions to be performed on the item listed in column 2. (For a detailed explanation of these functions, see paragraph B-2.)

d. Column 4. Maintenance Category. Column 4 specifies, by the listing of a work time figure in the appropriate subcolumn(s), the category of maintenance authorized to perform the function listed in column 3. This figure represents the active time required to perform that maintenance function at the indicated category of maintenance. If the number or complexity of the tasks within the listed maintenance function vary at different maintenance categories, appropriate work time figures will be shown for each category. The work time figure represents the average time required to restore an item (assembly, subassembly, component, module, end item, or system) to a serviceable condition under typical field operating conditions. This time includes preparation time (including any necessary disassembly/assembly time), troubleshooting/fault location time, and quality assurance/quality control time in addition to the time required to perform the specific tasks identified for the maintenance functions authorized in the maintenance allocation chart. The symbol designations for the various maintenance categories are as follows:

1 *Services - inspect, test, service, adjust, align, calibrate, and/or replace.*

2 *Fault locate/troubleshoot- the process of investigating and detecting the cause of equipment malfunctioning; the act of isolating a fault within a system or unit under test (UUT).*

3 *Disassemble/assemble - encompasses the step-by-step taking apart (or breakdown) of a spare/functional group coded item to the level of its least component identified as maintenance significant (i.e., assigned an SMR code) for the category of maintenance under consideration.*

4 *Actions - welding, grinding, riveting, straightening, facing, remachining, and/or resurfacing.*

C.....	Operator/Crew
O.....	Unit Maintenance
F.....	Direct Support Maintenance
H.....	General Support Maintenance
D.....	Depot Maintenance

e. Column 5. Tools and Equipment. Column 5 specifies, by code, those common tool sets (not individual tools) and special tools, TMDE, and support equipment required to perform the designated function.

f. Column 6. Remarks. This column shall, when applicable, contain a letter code, in alphabetic order, which shall be keyed to the remarks contained in section IV.

B-4. Explanation Of Columns In Tool And Test Equipment Requirements, Section III.

a. Column 1. Reference Code. The tool and test equipment reference code correlates with a code used in the MAC, section II, column 5.

b. Column 2. Maintenance Category. The lowest category of maintenance authorized to use the tool or test equipment.

c. Column 3. Nomenclature. Name or identification of the tool or test equipment.

d. Column 4. National Stock Number. The National stock number of the tool or test equipment.

e. Column 5. Tool Number. The manufacturer's part number.

B-5. Explanation Of Columns In Remarks, Section IV.

a. Column 1. Reference Code. The code recorded in column 6, Section II.

b. Column 2. Remarks. This column lists information pertinent to the maintenance function being performed as indicated in the MAC, section II.

SECTION II. MAINTENANCE ALLOCATION CHART

(1) GROUP NUMBER	(2) COMPONENT/ ASSEMBLY	(3) MAINTENANCE FUNCTION	(4) MAINTENANCE LEVEL				(5) TOOLS AND EQUIPMENT	(6) REMARKS
			UNIT	DS	GS	DEPOT		
			C	O	F	H	D	
01	GAS ALARM	INSPECT	0.2				3	A
		TEST	0.2				3	B
		ADJUST	0.2				1	B
		REPLACE		0.5			1,2	C
		REPAIR			4.0		1,2,3	D
		CALIBRATE		1.0	1.0		3	E

**SECTION III. TOOL AND TEST EQUIPMENT REQUIREMENTS
FOR
MAINTENANCE ALLOCATION CHART**

(1) TOOL/TEST EQUIP REF CODE	(2) MAINTENANCE CATEGORY	(3) NOMENCLATURE	(4) NSN	(5) TOOL NUMBER
1	C, O, F	TOOL KIT, GENERAL AUTOMOTIVE	5180-00-177-7033	(50980) SC 5180-90- CL-N26
2	C, O, F	SHOP EQUIPMENT AUTOMOTIVE MAINTENANCE & REPAIR: COMMON #1 (LESS POWER)	4910-00-754-0654	(19204) SC 4910- 95- CL-A74
3	C, O, F	MULTIMETER, 0-500V	6625-00-691-2453	

SECTION IV. REMARKS

REFERENCE CODE	REMARKS
A	The alarm system will be inspected/maintained in accordance with the instructions listed in Section 4 of this manual.
B	Monthly tests and adjustments will be accomplished in accordance with the instructions in Section 3 and Section 4.
C	Repairs at this level shall consist of replacement of defective parts and sensors.
D	Repairs beyond capability of DS shall be accomplished by replacement of unit and return of defective unit to manufacturer.
E	Calibration will be accomplished per instructions contained in Section 3.

APPENDIX C
COMPONENTS OF END ITEM AND BASIC ISSUE ITEMS LISTS
SECTION I. INTRODUCTION

C-1. Scope.

This appendix lists components of end item and basic issue items for the Gas Alarm to help you inventory items required for safe and efficient operation.

C-2. General.

The Components of End Item and Basic Issue Items Lists are divided into the following sections:

a. Section II. Components of End Item. This listing is for informational purposes only, and is not authority to requisition replacements. These items are part of the end item, but are removed and separately packaged for transportation or shipment. As part of the end item, these items must be with the end item whenever it is issued or transferred between property accounts. Illustrations are furnished to assist you in identifying the items.

b. Section III. Basic Issue Items. These are the minimum essential items required to place the Gas Alarm in operation, to operate it, and to perform emergency repairs. Although shipped separately packaged, BII must be with the shelter during operation and whenever it is transferred between property accounts. The illustrations will assist you with hard-to-identify items. This manual is your authority to request/requisition replacement BII, based on TOE/MTOE authorization of the end item.

C-3. Explanation of Columns.

The following provides an explanation of columns found in the tabular listings:

a. Column (1) - Illustration Number (Illus Number). This column indicates the number of the illustration in which the item is shown.

b. Column (2) - National Stock Number. Indicates the National stock number assigned to the item and will be used for requisitioning purposes.

c. Column (3) - Description. Indicates the Federal item name and, if required, a minimum description to identify and locate the item. The last line for each item indicates the CAGEC (in parentheses) followed by the part number.

d. Column (4) - Unit of Measure (U/M). Indicates the measure used in performing the actual operational/maintenance function. This measure is expressed by a two-character alphabetical abbreviation (e.g., ea, in, pr).

e. Column (5) - Quantity required (QTY RQR). Indicates the quantity of the item authorized to be used with/on the equipment.

SECTION II. COMPONENTS OF END ITEM

(1)	(2)	(3)	(4)	(5)
Illus	National Stock Number	Description CAGEC And Part Number	Usable On Code	Qty
	5930-00-132-8370	SWITCH, WARNING TEST (05083) NO. 355-052	EA	1
		CALIBRATION KIT (05083) P/N 23-7260	KT	1

SECTION III. BASIC ISSUE ITEMS

NOT APPLICABLE

APPENDIX D
ADDITIONAL AUTHORIZATION LIST
NOT APPLICABLE

D-1/(D-2 Blank)

APPENDIX E

EXPENDABLE/DURABLE SUPPLIES AND MATERIALS LIST

NOT APPLICABLE

E-1/(E-2 Blank)

By Order of the Secretary of the Army:

CARL E. VUONO
General, United States Army
Chief of Staff

Official:

THOMAS F. SIKORA
Brigadier General, United States Army
The Adjutant General

DISTRIBUTION:

To be distributed in accordance with DA Form 12-21A, Operator, Unit and Direct Support Maintenance requirements for Laboratory, Air Mobile, Aviation Fuel and Laboratory, Petroleum, MTD

☆ U.S. GOVERNMENT PRINTING OFFICE: 1990 554-123/20049

RECOMMENDED CHANGES TO EQUIPMENT TECHNICAL PUBLICATIONS

BE EXACT PIN-POINT WHERE IT IS				IN THIS SPACE, TELL WHAT IS WRONG AND WHAT SHOULD BE DONE ABOUT IT.
PAGE NO.	PARA- GRAPH	FIGURE NO.	TABLE NO.	

PRINTED NAME, GRADE OR TITLE AND TELEPHONE NUMBER	SIGN HERE
---	-----------



THEN...JOT DOWN THE DOPE ABOUT IT ON THIS FORM. CAREFULLY TEAR IT OUT, FOLD IT AND DROP IT IN THE MAIL.

SOMETHING WRONG WITH PUBLICATION

FROM: (PRINT YOUR UNIT'S COMPLETE ADDRESS)

DATE SENT

PUBLICATION NUMBER	PUBLICATION DATE	PUBLICATION TITLE
--------------------	------------------	-------------------

TEAR ALONG PERFORATED LINE

DA FORM 1 JUL 79 **2028-2**

PREVIOUS EDITIONS ARE OBSOLETE.

P.S.--IF YOUR OUTFIT WANTS TO KNOW ABOUT YOUR RECOMMENDATION MAKE A CARBON COPY OF THIS AND GIVE IT TO YOUR HEADQUARTERS.

The Metric System and Equivalents

Linear Measure

1 centimeter = 10 millimeters = .39 inch
 1 decimeter = 10 centimeters = 3.94 inches
 1 meter = 10 decimeters = 39.37 inches
 1 dekameter = 10 meters = 32.8 feet
 1 hectometer = 10 dekameters = 328.08 feet
 1 kilometer = 10 hectometers = 3,280.8 feet

Weights

1 centigram = 10 milligrams = .15 grain
 1 decigram = 10 centigrams = 1.54 grains
 1 gram = 10 decigrams = .035 ounce
 1 dekagram = 10 grams = .35 ounce
 1 hectogram = 10 dekagrams = 3.52 ounces
 1 kilogram = 10 hectograms = 2.2 pounds
 1 quintal = 100 kilograms = 220.46 pounds
 1 metric ton = 10 quintals = 1.1 short tons

Liquid Measure

1 centiliter = 10 milliliters = .34 fl. ounce
 1 deciliter = 10 centiliters = 3.38 fl. ounces
 1 liter = 10 deciliters = 33.81 fl. ounces
 1 dekaliter = 10 liters = 2.64 gallons
 1 hectoliter = 10 dekaliters = 26.42 gallons
 1 kiloliter = 10 hectoliters = 264.18 gallons

Square Measure

1 sq. centimeter = 100 sq. millimeters = .155 sq. inch
 1 sq. decimeter = 100 sq. centimeters = 15.5 sq. inches
 1 sq. meter (centare) = 100 sq. decimeters = 10.76 sq. feet
 1 sq. dekameter (are) = 100 sq. meters = 1,076.4 sq. feet
 1 sq. hectometer (hectare) = 100 sq. dekameters = 2.47 acres
 1 sq. kilometer = 100 sq. hectometers = .386 sq. mile

Cubic Measure

1 cu. centimeter = 1000 cu. millimeters = .06 cu. inch
 1 cu. decimeter = 1000 cu. centimeters = 61.02 cu. inches
 1 cu. meter = 1000 cu. decimeters = 35.31 cu. feet

Approximate Conversion Factors

To change	To	Multiply by	To change	To	Multiply by
inches	centimeters	2.540	ounce-inches	newton-meters	.007062
feet	meters	.305	centimeters	inches	.394
yards	meters	.914	meters	feet	3.280
miles	kilometers	1.609	meters	yards	1.094
square inches	square centimeters	6.451	kilometers	miles	.621
square feet	square meters	.093	square centimeters	square inches	.155
square yards	square meters	.836	square meters	square feet	10.764
square miles	square kilometers	2.590	square meters	square yards	1.196
acres	square hectometers	.405	square kilometers	square miles	.386
cubic feet	cubic meters	.028	square hectometers	acres	2.471
cubic yards	cubic meters	.765	square meters	cubic feet	35.315
fluid ounces	milliliters	29.573	cubic meters	cubic yards	1.308
pints	liters	.473	milliliters	fluid ounces	.034
quarts	liters	.946	liters	pints	2.113
gallons	liters	3.785	liters	quarts	1.057
ounces	grams	28.349	liters	gallons	.264
pounds	kilograms	.454	grams	ounces	.035
short tons	metric tons	.907	kilograms	pounds	2.205
pound-feet	newton-meters	1.356	metric tons	short tons	1.102
pound-inches	newton-meters	.11296			

Temperature (Exact)

°F	Fahrenheit temperature	5/9 (after subtracting 32)	Celsius temperature	°C
----	------------------------	----------------------------	---------------------	----

